

News from Rohde & Schwarz



Fast test platform
for upcoming mobile radio standards

Liquid-cooled TV transmitters
of extremely compact design

HF radiomonitoring
over any azimuth and distance

1999/V

165

Universal Radio Communication Tester CMU200 not only guarantees utmost measuring accuracy and speed but also maximum future-proofness. CMU200 is so fit for the future that it not only supports current standards such as GSM, AMPS, D-AMPS and CDMA but is also ready to integrate upcoming mobile radio standards of the third generation such as W-CDMA and CDMA2000 (page 4)



Photo 43 452

Articles

Werner Mittermaier; Walter Schmitz	Universal Radio Communication Tester CMU200 On the fast lane into the mobile radio future.....	4
Wilhelm Kraemer	Signal Generator SML01 Top-class economy generator	8
Valentin Sarreiter	UHF Transmitter Family NV/NH7000 Liquid-cooled TV transmitters for terrestrial digital TV.....	11
Michael Fischbacher	MPEG2 Realtime Monitor DVRM Digital broadcast networks: operation secured	14
Theodor Fokken	Miniport Receiver EB200/Compact Receiver ESMC Mini-receivers: remote control lends weight to network role	16
Klaus Fischer; Dr Christof Rohner	Test Antenna ULTRALOG HL562 No tiresome changing of antennas: universal and broadband EMC measurements	18
Ludwig Nielsen; Dr Christof Rohner	HF antenna systems for radiomonitoring Complete coverage tailored to requirements: HF radiomonitoring over any azimuth and distance.....	20

Application notes

Holger Jauch	W-CDMA Rx/Tx Test System TS8950A Startup of 3G air interface simulator.....	23
--------------	--	----

Rudolf Reimann	MONLOC software GSM data link networks direction finders	26
Wilhelm Kraemer	Microwave Signal Generator SMR Testing receivers for satellite telemetry signals	28
Wolfgang Krall	NetHawk™ Analysis and Simulation Software Wired measurements for mobile radio systems.....	30

Panorama

Günter Hornauer	Key position in IT security: more competence for SIT	32
-----------------	--	----

Regular features

Stefan Böttinger	CD-ROM: Signal generators – from baseband to microwave.....	29
	Information in print.....	34
	Press comments.....	35
	Newsgrams.....	36
Dr Ralph Wernsdorf	Final article: How random is chance? (part 2 and conclusion)	38

Rohde & Schwarz is launching a new generation of liquid-cooled UHF transmitters perfectly timed for the startup of regular operation of terrestrial digital TV (DVB-T) by many countries. Thanks to the modular design, transmitter systems for both digital and analog TV can be created, meeting future requirements and featuring high economy and reliability (page 11)



Photo 43 392/7

Imprint

Published by ROHDE & SCHWARZ GmbH & Co. KG · Mühlldorfstraße 15 · 81671 München · Support Center: Tel. (+49) 018 05 12 42 42 · E-mail: customersupport@rsd.rsd.de · Fax (+49 89) 41 29-3777
 Editor and layout: Ludwig Drexl, Redaktion – Technik (German) · English translation: Dept. 5CL4
 Photos: Stefan Huber · Circulation 90 000 six times a year · ISSN 0028-9108 · Supply free of charge through your nearest Rohde & Schwarz representative · Printed in Germany by peschke druck, München
 Reproduction of extracts permitted if source is stated and copy sent to Rohde & Schwarz München.

Universal Radio Communication Tester CMU200

On the fast lane into the mobile radio future

Maximum production throughput, extremely high measuring accuracy and speed, multistandard/multiband, future-proofness – these and other similarly exacting demands are familiar in the design and manufacture of radiotelephones. Rohde & Schwarz, world market leader in mobile radio testers, has responded to the challenge by developing an innovative and unique test platform: Universal Radio Communication Tester CMU200 (FIG 1). The company's decades of experience were a vital prerequisite for tackling such a project in the first place, but many new approaches had to be taken at the same time.

Modular concept guarantees future-proofness

The rigid demands can only be met by combining state-of-the-art hardware and software in a highly modular and thus flexible concept. The result is CMU200, a radiocommunication tester that not only guarantees utmost measuring accuracy and speed but also maximum future-proofness. The latter is a must for modern testers, given

FIG 1 Universal Radio Communication Tester CMU200 is way ahead of conventional testers: total measuring accuracy is better by a factor of 3, one-shot measurements are up to ten times faster

further development of existing standards like GSM into multi-slot and EDGE, and the possibility of today's mobile radio standards like GSM and IS136 merging. CMU200 is so fit for the future that it not only supports current standards such as GSM, AMPS, D-AMPS and CDMA but is also ready to integrate upcoming mobile radio standards of the third generation such as W-CDMA and CDMA2000.

Plus, the extendable, mainly digital hardware platform (FIG 2) can accommodate an extra transceiver unit for future multimode applications. That makes simultaneous measurement to two different mobile radio standards a straightforward implementation.



The modular structure is maintained throughout CMU200 software. Each functional group is implemented in dynamic link libraries (DLLs), software libraries that are loaded in real-time when required. Intelligent control ensures that realtime conditions required for measurement and signaling are not violated by loading. The DLL structure makes for scalability of CMU200 software, so there is no loss of time even if a large number of network standards are implemented.



Photo 43238/2



CMU200 – versatile in application

- Production
 - module tests
 - final tests
- Quality management
- Development
 - module design
 - RF development
 - function tests
- High-end service
- Basic platform for test systems
- BTS simulation

common standards – will cut down on setup times in production for example. CMU200 is a multistandard test platform that, thanks to its pronounced modularity, is optimally prepared for today's and tomorrow's needs and offers maximum safety of investment. The tester allows measurements in the GSM900, GSM1800/1900 bands and is easily extended to other mobile radio standards like IS95 (CDMA), IS136 (US cellular), AMPS, or to future technologies like Bluetooth or W-CDMA. The result is that mobile phones to different standards can be

FIG 2 Block diagram of CMU200 (blue: optional extensions)

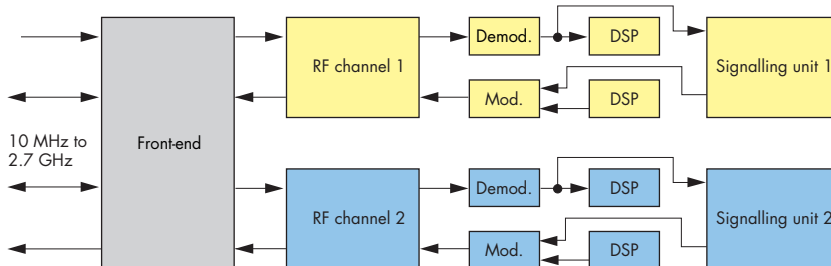

Multistandard capability safeguards investment

For rapid response to the continuously changing requirements of the mobile radio market, test equipment must have multistandard capability. Only highly versatile testers – supporting all

manufactured on one and the same production line.

The RF modules of CMU200 cover the entire frequency range from 10 MHz through 2.7 GHz, which is important for simple software upgrades to future standards like GSM400.

Fast
Accurate
**Future-
proof**

GSM

IS 136

AMPS

CDMA

Bluetooth

W-CDMA

Extremely accurate, incredibly fast measurement

CMU200 is a clear front-runner in terms of measuring accuracy. Its innovative error correction enhances absolute measuring accuracy threefold compared with conventional testers. This reduces the number of rejects and improves production quality. The secret: internal temperature changes are detected during operation and corrected virtually in realtime. Another factor making for extremely high accuracy is optimized design of the RF modules. VSWR at the RF input/output is <1.2. This yields an extremely high total accuracy of 0.5 dB in power measurements, and an output level accuracy of 0.6 dB.

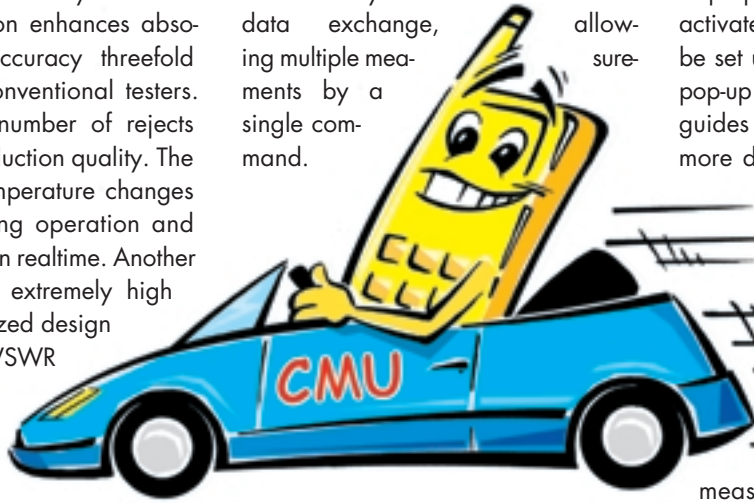

of measurements minimize test times, speed up adjustments and thus considerably boost production throughput. Optimized IEC/IEEE-bus drivers make for extremely fast and smooth data exchange, allowing multiple measurements by a single command.

High reliability for uninterrupted production

CMU200 is a reliable partner in production: a new hardware concept with power consumption well below 200 W guarantees low generation of heat and thus failsafe operation.

Exemplary operating concept

A model user prompting concept ensures that all menus are accessi-

ble at any time, ie independently of signalling status. For example, in a GSM900 call setup you can change to the GSM1800 functional group to prepare for handover. When you activate menus that require a call to be set up before outputting results, a pop-up menu opens automatically and guides you through to call setup. For more detailed configurations, further pop-up menus are available, split into signalling and functional groups and measurement settings (FIG 3). A hotkey bar at the bottom enables switch-over between measurement menus (FIG 4). The menus can easily be redefined, allowing for fast switchover between the major applications.

The complex procedures involved in testing modern dual- and triple-band mobiles have nearly doubled the time taken by conventional testers. This presents no problem for CMU200. It handles one-shot measurements up to ten times faster. The use of advanced, high-performance digital signal processors – with special processors assigned to different measurements – and optimized parallelizing

The colour display makes for transparent presentation of the wealth of information. For example, results exceeding tolerances are highlighted in colour. Two display modes are available for remote control of CMU200: the display is switched off for maximum measuring speed, and in the text mode commands and acknowledgments can be analyzed.

FIG 3 Pop-up menus guide the user simply and speedily through call setup and clear-down procedures

FIG 4 GSM Overview menu shows all important GSM parameters and results. Hotkeys (bottom) enable fast changing to special menus

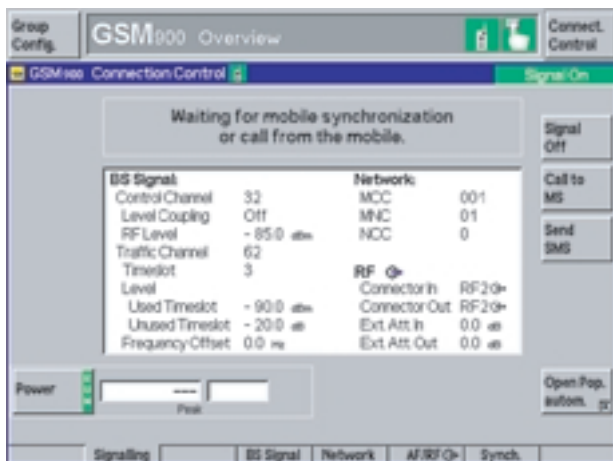

Optimally equipped for general-purpose measurements

The basic unit itself offers ample, non-standard-specific general-purpose measurement functions. In addition to an RF generator, CMU200 incorporates a spectrum analyzer with a continuous frequency range, numerous resolution bandwidths and convenient operation (FIG 5). In the zero span mode (FIG 6), which is of major importance in digital network standards (TDMA systems), CMU200 features a special operating mode offering comprehensive trigger and time functions (pre-trigger, delay, timebase, slope). This basic configuration enables a variety of measurements on production lines, in development labs, and in high-end servicing.

Featuring such excellent characteristics, it is not surprising that CMU200 leaves other testers far behind. A CD-ROM demonstrating the wealth of functions of CMU200 by numerous examples and animations is available from your local Rohde & Schwarz representative.

Werner Mittermaier;
Walter Schmitz

REFERENCES

- [1] Mittermaier, Werner: Digital Radiocommunication Testers CMD65 and CMD80 – Multiband and multimode testers for mobile-radio telephones. News from Rohde & Schwarz (1997) No. 155, pp 6–8
- [2] Gresser, Klaus; Holzmann, Gottfried: Digital Radio Testers CTS65 and CTS60 – All-rounders in servicing GSM and DECT mobile phones. News from Rohde & Schwarz (1998) No. 158, pp 7–9

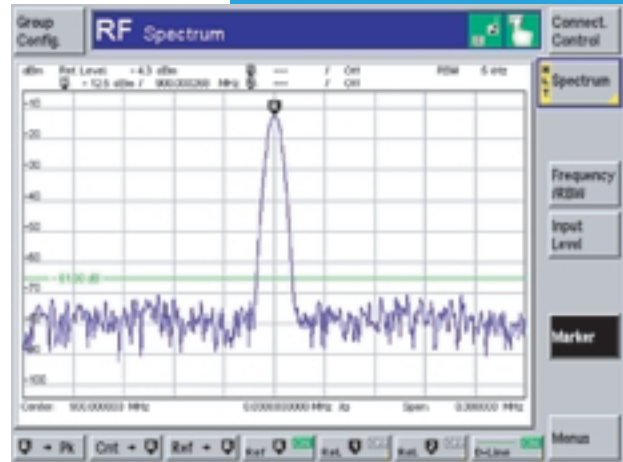

FIG 5
Functions such as markers and display lines are valuable tools in result analysis

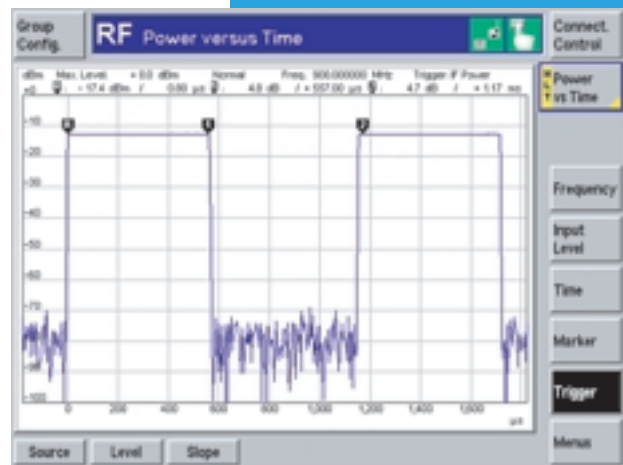

FIG 6
Convenient analysis of TDMA signals in zero span mode

Condensed data of CMU200

Frequency range	10 MHz to 2.7 GHz
Accuracy of power meter	0.5 dB
Accuracy of RF generator	0.6 dB
VSWR of RF inputs/outputs 1 and 2	better than 1:1.2
Frequency-selective power measurement	bandwidth 10 Hz to 1 MHz
Spectrum analyzer	10 MHz to 2.7 GHz

Measurements at a glance

Network-independent measurements	generator power measurement (narrowband/ broadband) spectrum power versus time power measurement power versus time power versus PCL phase/frequency error spectrum due to modulation/switching bit error rates (BER, RBER, FER, fast BER) timing error
GSM: measurements with signalling	
GSM: measurements without signalling	power measurement power versus time phase/frequency error spectrum due to modulation/switching

Reader service card 165/01

Signal Generator SML01

Top-class economy generator

Despite its amazingly attractive purchase price, the new Signal Generator SML01 (FIG 1) comes up with a variety of technical benefits. For example, it features a wear-free electronic attenuator guaranteeing short level setting times. Users in production and servicing, EMC testing and design alike will highly appreciate this feature. In frequency synthesis too, our engineers have taken new approaches and created a spectrally pure synthesizer with extremely short setting times previously only found in high-end equipment.



Photo 43 412/3

FIG 1 Great inner qualities and surprisingly compact outward appearance: the 19" case of SML01 is only 88 mm high and 450 mm deep. This makes the generator an attractive signal source for rack or desktop applications. Operation is by "EasyWheel" (FIG 2)

Modulation: classic modes

SML01 generates amplitude-, frequency- and phase-modulated RF signals in the frequency range 9 kHz to 1.1 GHz – just what is needed in all classic receiver measurements. Of course the FM modulator provides stereo modulation too with the aid of an external signal.

To generate sinusoidal modulation signals, an AF generator is built into SML01 covering the frequency range 0.1 Hz to 1 MHz. Its output signal is brought out at a separate connector

and thus available for external applications. For two-tone modulation the AF generator can be operated in conjunction with an external signal source.

Pulse modulation for EMC applications or measurements in the radar IF range? Again no problem for SML01: adding the option SML-B3, these functions are easily implemented. SML-B3 not only comprises a high-grade pulse modulator but also a fully equipped pulse generator whose signal is brought out at an extra output.

All modulation modes can be operated simultaneously. Only frequency and phase modulation cannot be combined since they are generated by the same modulator.

Frequency synthesis: like the "big boys"

In terms of frequency accuracy and spectral purity, SML01 is equal to high-end Rohde & Schwarz signal generators in every way. Frequency setting is crystal-controlled with 0.1 Hz resolution. Fitted with option SML-B1 (OCXO reference oscillator), SML01 satisfies even the most stringent frequency accuracy requirements.

Particularly noteworthy is SSB phase noise (FIGs 3 and 4). A typical value of -128 dBc (at 1 GHz, 20 kHz from carrier, 1 Hz bandwidth) was simply unknown to date in this instrument class. FIG 3 shows a typical characteristic at 1 GHz for carrier offsets 1 Hz to

10 MHz. This excellent noise performance – just like the outstanding spurious suppression of typically -76 dBc – was achieved by sophisticated direct digital frequency synthesis (DDS). This concept at the same time means short frequency setting times (typ. 7 ms) for SML01. FIG 3 further shows broadband noise of typically -150 dBc (at >2 MHz from carrier), which meets the most exacting demands.

Level: electronic setting

The tough conditions of day-to-day use in production are a measure of the worth of any signal generator. Here, precision and speed and above all maximum reliability are called for. This applies in particular to the attenuator in the output path of the signal generator. While mechanical attenuators, which are frequently used, fully meet requirements in terms of level accuracy, they leave a great deal to be desired when it comes to setting speed and service life.

Not so SML01: its electronic attenuator handles any number of setting operations without any wear – and this with typical setting times of 5 ms. And because of the excellently devised frequency response compensation of the RF level by means of the SML01 micro-processor, level accuracy (typ. 0.5 dB) well matches that of any signal generator using a mechanical attenuator (FIG 5).

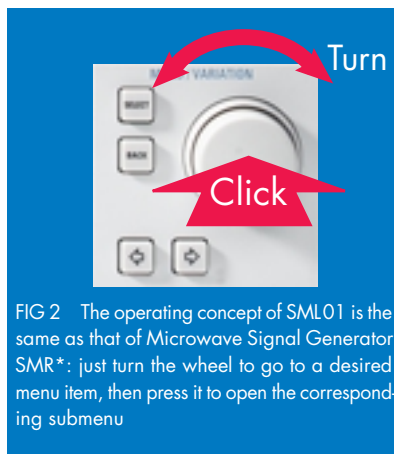

FIG 2 The operating concept of SML01 is the same as that of Microwave Signal Generator SMR*: just turn the wheel to go to a desired menu item, then press it to open the corresponding submenu

The remaining RF level specifications are quite impressive too. For example, levels from -140 dBm to $+13$ dBm can be set in 0.1 dB steps – with over-range even up to $+19$ dBm. Of course, neither a mechanical nor an electronic attenuator performs level setting without interruption. SML01, therefore, like signal generators with a mechanical attenuator, offers the “non-interrupting” level setting mode, allowing level variation by typically 30 dB. This makes SML01 an ideal choice for squelch tests.

Applications: fit in every respect

Receiver measurements

These measurements belong to the classic applications of SML01. Featuring

low residual FM of typically 0.5 Hz (at 1 GHz, weighting bandwidth 0.3 kHz to 3 kHz to CCITT) and low SSB phase noise as well as high spurious suppression, the signal generator is ideal for all in-channel measurements on receivers.

This also applies to its use as a noise source outside the receive channel. Here the low broadband noise is an additional advantage. Since SSB phase noise is very low even at several hundred kHz from the carrier, blocking measurements pose no problem.

Sensitivity measurements call for high level accuracy, especially at low RF levels. The signal generator should also feature adequate RF shielding – in particular with unshielded receivers or equipment with an integrated antenna (eg pagers). SML01 fully meets both requirements.

EMC measurements

EMC measurements, such as of electromagnetic susceptibility, are usually carried out with a power amplifier connected after SML01. The amplifier is extremely sensitive to fast level changes such as overshoots or dropouts, which may even cause damage. The following two characteristics of SML01 are, therefore, particularly valuable: level changes are practically without overshoots, and the non-interrupting level setting prevents RF level dropouts during level changes (FIG 6).

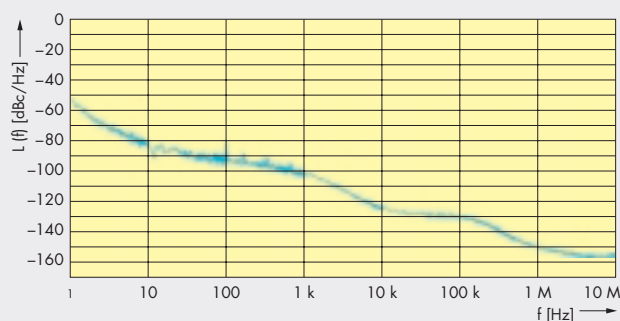

FIG 3 Typical SSB phase noise at 1 GHz

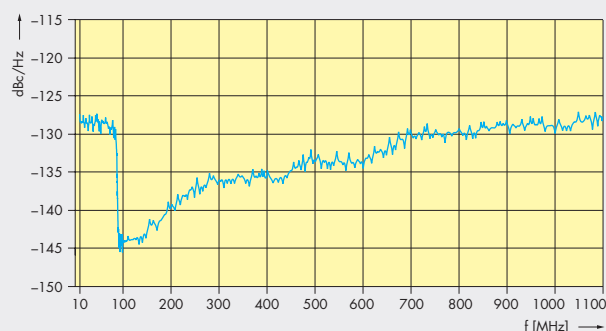
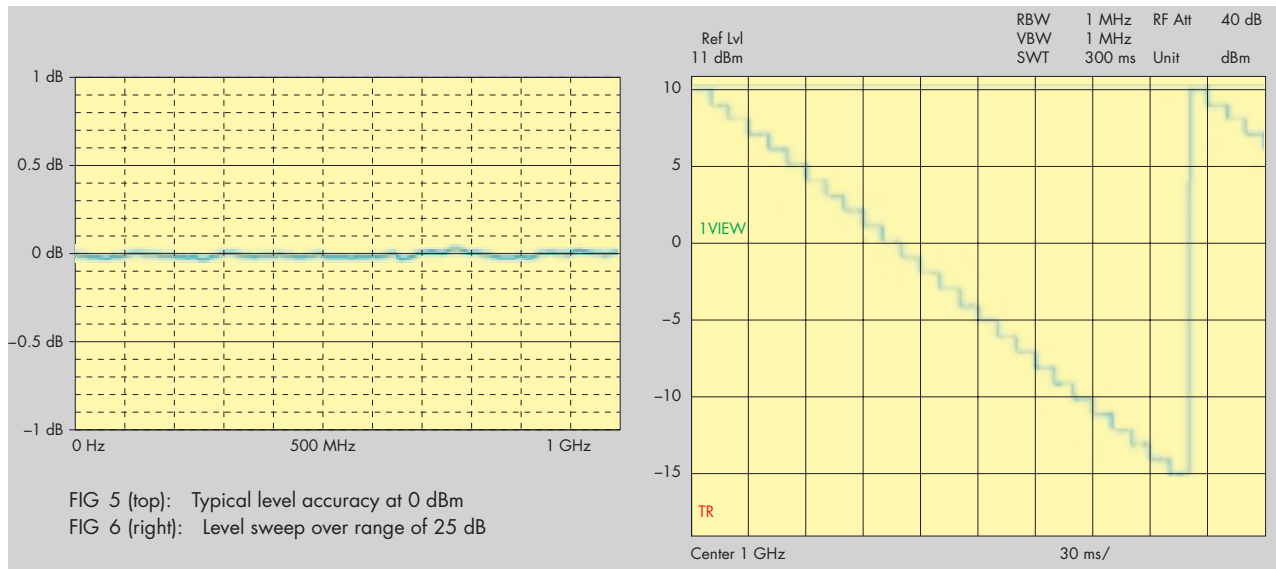

FIG 4 Typical SSB phase noise versus carrier frequency (20 kHz from carrier)



Due to the widespread use of digital radiotelephones, growing importance attaches to testing the immunity of these units to high-frequency electromagnetic fields. The European draft standard ENV 50204 specifies a relevant test method. The method can basically be implemented with an SML01 fitted with an optional SML-B3 pulse modulator. The measurement is carried out using a pulse-modulated carrier frequency of 900 MHz \pm 5 MHz, with the pulse generator set to a period of 5 ms and a pulse width of 2.5 ms. In this way the generator simulates interference caused by TDMA signals.

Servicing

SML01 is compact and lightweight. And another plus for field use: it can be controlled both via an IEEE bus interface and a serial RS-232-C interface. This allows straightforward operation from a notebook PC without an IEEE bus card.

In the servicing of transceivers or transmitters, there is a risk of RF power being inadvertently applied to the generator RF output. SML01 has a protective circuit integrated in its output that prevents the unit from being damaged (this applies to reverse power up to 50 W).

All in all: an investment you will not regret

When it comes to reliability, SML01 makes no compromises either. Should a fault ever occur, the built-in diagnostic system helps to drastically reduce repair times. So SML01 is a safe investment, not only due to the favourable purchase price but also to the low follow-up costs and the long calibration interval of at least three years.

Wilhelm Kraemer

* Kraemer, Wilhelm: Microwave Signal Generators SMR – Microwave in handy size. News from Rohde & Schwarz (1999) No. 162, pp 4–6

Condensed data of SML01

Frequency range	9 kHz to 1.1 GHz
Resolution	0.1 Hz
Setting time	<10 ms
Harmonics	<-30 dBc
Spurious	<-70 dBc
SSB phase noise	<-122 dBc/Hz
(f = 1 GHz, carrier offset 20 Hz)	
Residual FM to CCITT (f = 1 GHz)	<4 Hz
Level	-140 dBm to +13 dBm (+19 dBm)
Resolution	0.1 dB
AM (3 dB bandwidth)	0 to 100 % (DC to 50 kHz)
FM (3 dB bandwidth)	max. 1 MHz (DC to 500 kHz)
ϕ M (3 dB bandwidth)	max. 10 rad (DC to 100 kHz) max. 2 rad (DC to 500 kHz)
Pulse modulation (option SML-B3)	
On/off ratio	>80 dB
Rise/fall time	<20 ns
AF generator	0.1 Hz to 1 MHz
Pulse generator (option SML-B3)	
Pulse period	100 ns to 85 s

Reader service card 165/02

UHF Transmitter Family NV/NH7000

Liquid-cooled TV transmitters for terrestrial digital TV

Rohde & Schwarz is launching a new generation of liquid-cooled UHF transmitters perfectly timed for the startup of regular operation of terrestrial digital TV (DVB-T) by many countries. The compact design facilitates the installation of new DVB transmitters at existing sites where space normally is very restricted. Thanks to modular design, transmitter systems for both digital and analog TV can be created, meeting future requirements and featuring high economy and reliability.

Latest technology with special features

The new water-cooled UHF Transmitter Family NV/NH7000 in LDMOS (lateral diffused metal oxide silicon) technology meets all requirements of terrestrial TV standard DVB-T to ETS 300744 and those of the familiar PAL, SECAM and NTSC standards by suitable configuration of the digital exciter. The family of equipment is dual-sound compatible to IRT or NICAM and can also be configured to comply with the American ATSC standard for digital TV.

Transmitters are available for DVB-T from 400 W to 5 kW (seven power classes) and for analog TV from 2 kW to 40 kW (five power classes). Their main characteristics are:

- latest LDMOS technology for power amplifiers (high gain, high linearity)
- very compact design (low space requirements) through liquid cooling
- digital equalization (accurate reproducibility of settings)
- high redundancy for high availability
- low installation outlay
- simple swap of modules during operation

Modular not only for output power

The modular transmitters chiefly consist of:

- digital exciter
- power amplifier with integrated power supply
- transmitter rack (with vision/sound diplexer for analog TV)

The transmitters with maximum output power of 2.5 kW for DVB (FIG 1) or 10 kW for analog TV require very little space. They are accommodated in a 630 mm wide rack together with other components such as filters, power couplers and water distribution system. To produce higher power, a second rack with amplifiers is simply added and combined via 3 dB couplers.

The transmitters are therefore ideal for setting up new DVB networks at existing sites where space often is very restricted. On the one hand, this reduces the costs for the network operator. On the other, it is also very important for the acceptance of the new medium, because all household roof antennas would have to be realigned if the new system were to be installed at a new site.

Despite the compactness of the new transmitter family all its modules are easy to access and service. The ampli-



FIG 1 Space-saving DVB transmitter for 2.5 kW accommodated in a single rack

FIG 2 Block diagram of DVB transmitter

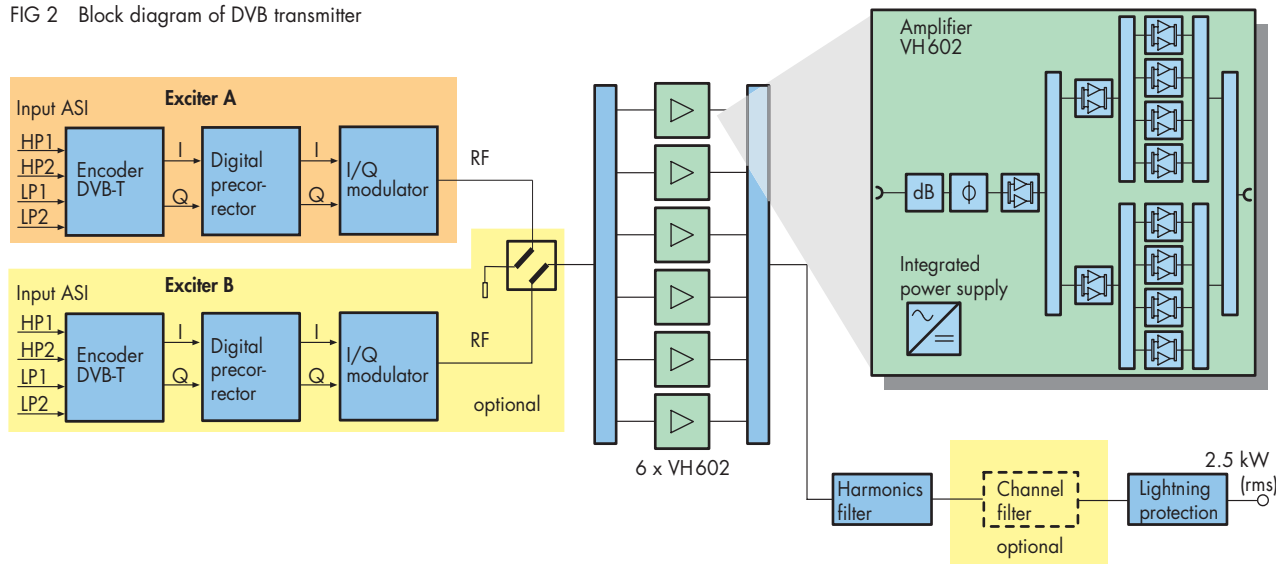

fier plug-ins have self-engaging connectors and are hot swappable. The connectors for the cooling system or RF output power can be provided at either the top or bottom. This means that the transmitters can be flexibly integrated into existing infrastructure.

Modules in detail

The newly developed **exciter** comprises the following modules:

- encoder for analog TV or DVB-T or ATSC
- digital precorrector

- modulator
- synthesizer
- controller for transmitter control unit
- control panel with display
- motherboard and power supply

The individual modules are of very compact design, so two complete exciters including the transmitter control unit with automatic switchover can be accommodated in a 19-inch frame in the transmitter rack.

The reference frequency for the synthesizer can be provided by the inte-

grated GPS receiver or from an external module. An emergency control circuit on the motherboard maintains transmitter operation in case of a fault or failure.

Power Amplifier VH602 (FIG 3) supplies 440 W DVB power or 2 kW sync peak power. Depending on the configuration, it is broadband from 470 MHz to 650 MHz or 650 MHz to 860 MHz and consists of a pre-driver with integrated input level monitor, level and phase controller, AB driver and eight AB output stages. The output stage modules are combined by

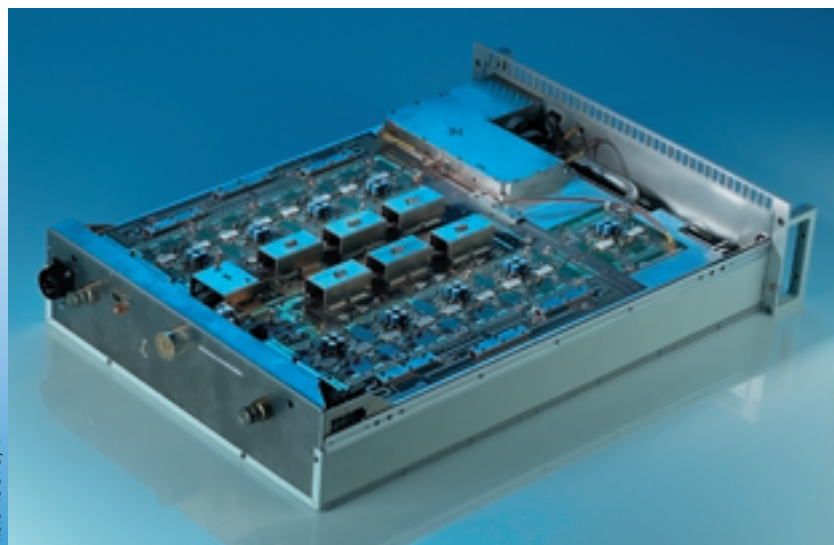

FIG 3 Protective circuits guard Power Amplifier VH602 against reflection and overtemperature

Photo 43395/1

couplers in suspended-substrate technology with total gain of approx. 63 dB. The power couplers with integrated directional couplers for control and monitoring are printed circuits requiring no adjustment. An intelligent control system prevents the other modules being overdriven if one breaks down, ensuring that all remain set at the same level and operating point. The amplifier plug-in has protective circuits to guard against reflection and overtemperature. A monitor displays faults on the front panel of the plug-in and sends a fault message to the transmitter control unit. The RF output level, phase and threshold of the output power can be set on the front panel.

The plug-in is set up on a special heat sink that ensures optimum cooling of the power components and at the same time acts as a carrier for all the modules.

The **power supply** is installed on the underside of the heat sink and is fed direct from a three-phase AC supply.

An integrated radial fan ensures that the residual heat of those components that are not directly mounted on the water duct of the heat sink is taken up by the cooling system via a heat exchanger. This makes for optimum

cooling within the plug-in and minimizes heat dissipation to the room outside.

The **cooling system** (outside the transmitter rack) consists of one pump unit for each transmitter rack with two pumps connected in series for full redundancy. To ensure optimum operation at temperatures down to -30°C , each pump unit is equipped with a 3-way mixer that is held at a constant inlet temperature.

A cooler assigned to each pump unit is installed outside the transmitter room. For reasons of redundancy, the cooler is equipped with two fans operating in active standby.

The complete transmitter is operated by PC software under Windows™ or from the display integrated in the control panel.

Anyone investing in new analog TV transmitters can be sure that an investment of this kind will not be lost when the network goes digital. Since the two transmitter types are of practically identical design, retrofitting them to a new digital standard later on is cost-efficient and easy.

Valentin Sarreiter

Operating principle (FIG 2)

The MPEG data stream is applied to the DVB encoder via the asynchronous serial interface (ASI). The MIP (megaframe initialization packet) decoder in the input section of the module allows automatic setting of the coder mode, evaluates the time stamp and controls delay compensation. The exciter is therefore ideal for use in single-frequency networks. This is followed by channel coding and modulation in line with ETS 300744.

The subsequent digital precorrector receives the DVB signal as a digital baseband signal with inphase and quadrature component. It consists of the optional group delay equalizer and the linearity precorrector. The latter pre-corrects the instantaneous amplitude and phase of the signal and so can optimally adapt it to the power amplifier characteristic. Conversion to the RF in the modulator is by direct modulation after the digital/analog converter.

The output power of the modulator is taken to the power amplifiers via a splitter. The RF power of the individual amplifiers (only six VH602 plug-ins are required for 2.5 kW DVB) is combined via 0° power couplers of triplate design. The power couplers and the water collector tube form a mechanical unit permitting the power loss of the associated absorption resistors to be dissipated via the cooling water.

The sum power is available after a harmonics filter and a dual-mode bandpass (option) with six or eight circuits at the output.

Condensed data of NV/NH7000

Frequency range	470 MHz to 860 MHz
RF output power	400 W to 5 kW (DVB-T) 2 kW to 40 kW (analog TV)
Interfaces	RS-232-C and RS-485
Optional	parallel interface (for messages and commands)
TV standards, digital	DVB-T, ATSC
TV standards, analog	B, G, D, K, M, N, I
Colour transmission	PAL, NTSC, SECAM
Sound transmission	dual-sound coding to IRT or FM single sound and Nicam 728 (-13 dB/-20 dB) or FM single sound (-10 dB)

Reader service card 165/03

MPEG2 Realtime Monitor DVRM

Digital broadcast networks: operation secured

Digital transmission of TV signals by MPEG2 transport streams is on the advance worldwide. Besides existing transmission media, ie satellite and in many places cable, nationwide terrestrial transmitter networks are planned or already being installed in many countries. Ensuring reliable operation of such complex networks, which involve variation of the structure and contents of transport streams at many points, makes great demands on monitoring systems. This is where MPEG2 Realtime Monitor DVRM comes into its own, featuring comprehensive monitoring functions and versatile control and signalling capabilities.

Secure operation of broadcast networks – a complex task

Transport streams in broadcast networks are complex and branch at many points: local and regional cable headends or terrestrial transmitters allow broadcasting of local and regional program packages. Moreover, satellites, cables and terrestrial transmitters are networked for program feed (FIG 1). Network operators must guarantee error-free transmission of a transport stream (TS) and be able to verify this for any given time. To begin with, "error-free" means that transport streams have to be provided with structure and syntax in conformance with MPEG2

and DVB or the North-American ATSC. Great importance also attaches to checking TS contents, ie the services, in networks as these are contributed by various sources and packed into different, site-specific transport streams. The available bandwidth affects quality and cost of transmission, so measuring the data rate of each individual stream of the overall TS stream is indispensable.

DVRM offers complete monitoring

Realtime Monitor DVRM (FIG 2) monitors transport streams in realtime to

DVB Measurement Guidelines ETR290 and ATSC. In addition, it checks the presence and repetition rates of "other_tables" (NIT_other, SDT_other, EIT_other). If these are missing, a receiver is unable to find the programs of other transport streams transmitted in a broadcasting network.

DVRM measures the data rates for the programs and each individual service. It also takes into account the sub-streams carrying the service information defined by the standards.

A particular asset is that DVRM carries out a comprehensive check of transport stream contents. Besides monitoring

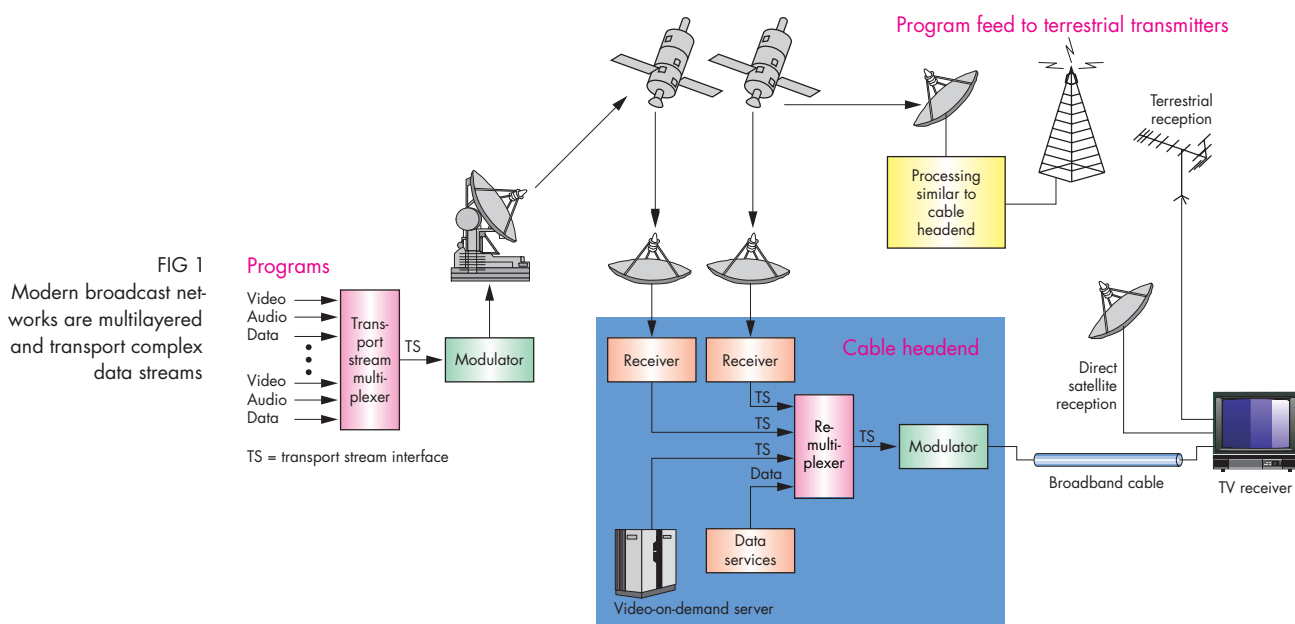

FIG 1 Modern broadcast networks are multilayered and transport complex data streams

TS = transport stream interface

MPEG 2



Photo 43410/3

FIG 2 DVRM – specialist for blanket monitoring of broadcast networks

the TS_ID to identify the correct TS, it continuously compares its complete structure with a template that defines all programs contained in the TS as well as the associated services for each program.

DVRM integration into network-wide monitoring systems

All instrument settings and the polling of results are remotely controlled. The supplied Windows™ program allows fast configuration of DVRM, clearly presents measurement results and the transport stream structure together with the data rates and offers special functions such as continuous recording of comprehensive measurement reports on a storage medium of the controller. DVRM further supports Stream Explorer™ software, which allows in-depth analysis of the transport stream [1].

Both the control software under Windows™ and Stream Explorer™ offer COM (component object model) and DCOM (distributed COM) software interfaces [2]. This means that all functions can be made available

to central monitoring software both locally (COM) and via a data network link (DCOM).

Apart from comprehensive measured-value acquisition via the remote-control interface, DVRM offers hardware signalling capability via relay contacts. Each of the twelve contacts can be assigned one error parameter or any combination of them. Closed or open contact signalling of errors is selectable. DVRM thus ensures complete monitoring of complex networks.

Michael Fischbacher

REFERENCES

- [1] Fischbacher, Michael; Rohde, Werner: PC software for MPEG2 dream team DVG/DVMD. News from Rohde & Schwarz (1997) No. 154, p 29
- [2] Finkenzeller, Richard; Fischbacher, Michael: MPEG2 transport stream analysis in networked DVB monitoring system using Stream Explorer software. News from Rohde & Schwarz (1998) No. 159, pp 24–25

Condensed data of DVRM

Input signals	transport stream to ISO/IEC 1-13818
Length of transport stream packets	188/204 bytes (DVB), 188/208 bytes (ATSC)
Data rates of transport stream	0.6 to 54 Mbit/s
Signal inputs	1 x TS parallel (to DVB-A010), 2 x TS-ASI (to DVB-A010) for DVB 1 x SMPTE 310 and 1 x TS-ASI for ATSC
Measurements	– parameters to ETR290 (adjusted for ATSC) – TS structure monitoring – data rates of overall stream, programs and substreams (PID) – monitoring of TS_ID – monitoring of “other_tables” (only DVB) – paradigm condition (only ATSC) – trigger on error
Interfaces	RS-232-C, 12 relay contacts

Reader service card 165/04

Miniport Receiver EB 200/Compact Receiver ESMC

Mini-receivers: remote control lends weight to network role

These two compact receivers for searching, detecting and displaying signals in the 10 kHz to 3 GHz range can be remote-controlled in all their functions and thus integrated – by optional software – into large networks, eg nationwide monitoring systems. To simplify entry into what can be a fairly complex application, Rohde & Schwarz is offering a version of the remote-control software that is reduced in its scope of functions and price.

Photo 43017/1

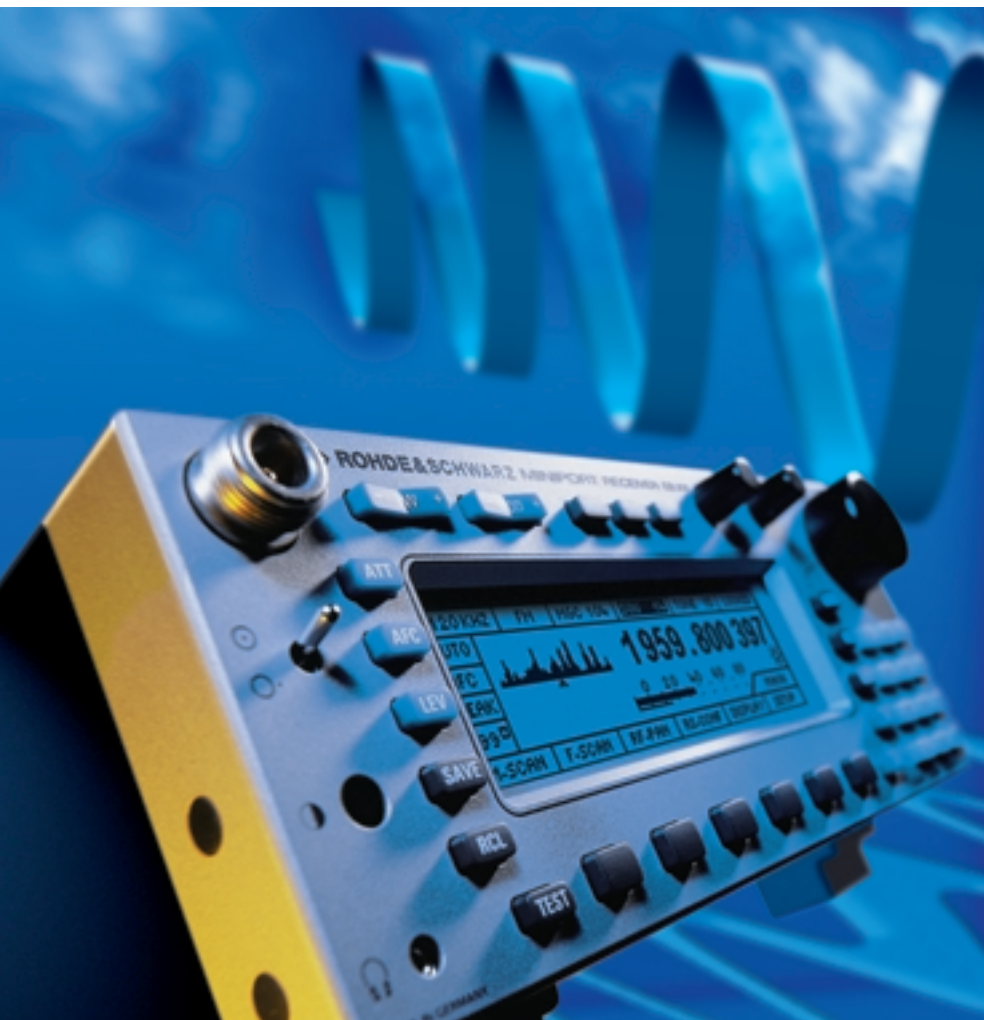

FIG 1
Favourably priced, compact Miniport Receiver EB200 can also be integrated into computer-controlled, stationary monitoring systems thanks to its remote-control interface

Miniport Receiver EB 200 (FIG 1) and Compact Receiver ESMC, these two extremely compact units meet all the requirements for searching, detect-

ing and displaying signals in the frequency range from 10 kHz to 3 GHz. Both receivers offer a fast RF spectrum overview: ESMC comes with an analog scan option and EB200 with its optional DIGI scan. These fast, standalone receivers for searching and monitoring not only feature many manual measurement modes such as frequency scan, memory scan or RF

spectrum. They can also document and store detected signals via their LAN interface and optional remote-control software, enabling their integration into complex, nationwide monitoring systems.

Rohde & Schwarz offers two different software packages for the remote control of blanket systems. RAMON, used in the military field, is for fast frequency detection and transfer to support monitoring receivers, while ARGUS is intended for civil applications, eg for authorities with frequency management tasks such as long-term monitoring of specific frequency bands. These comprehensive and powerful software packages are able to mesh numerous Rohde & Schwarz units such as antennas, direction finders and analyzers into nationwide monitoring systems and ensure convenient control and management.

To simplify entry into ARGUS, Rohde & Schwarz is offering ARGUS MON software – a version reduced in functionality and consequently price – for remote control of EB 200 or ESMC. This version, also available as demo software, allows remote control of all settings, measurement and scan functions of the two receivers and saving of measured data such as frequency, level, offset, data and time. This special ARGUS version is used to control only one EB200 or ESMC and costs a fraction of the complex system software. Extensive, special measurement modes such as intermodulation analysis, automatic or DF measurement mode are not contained.

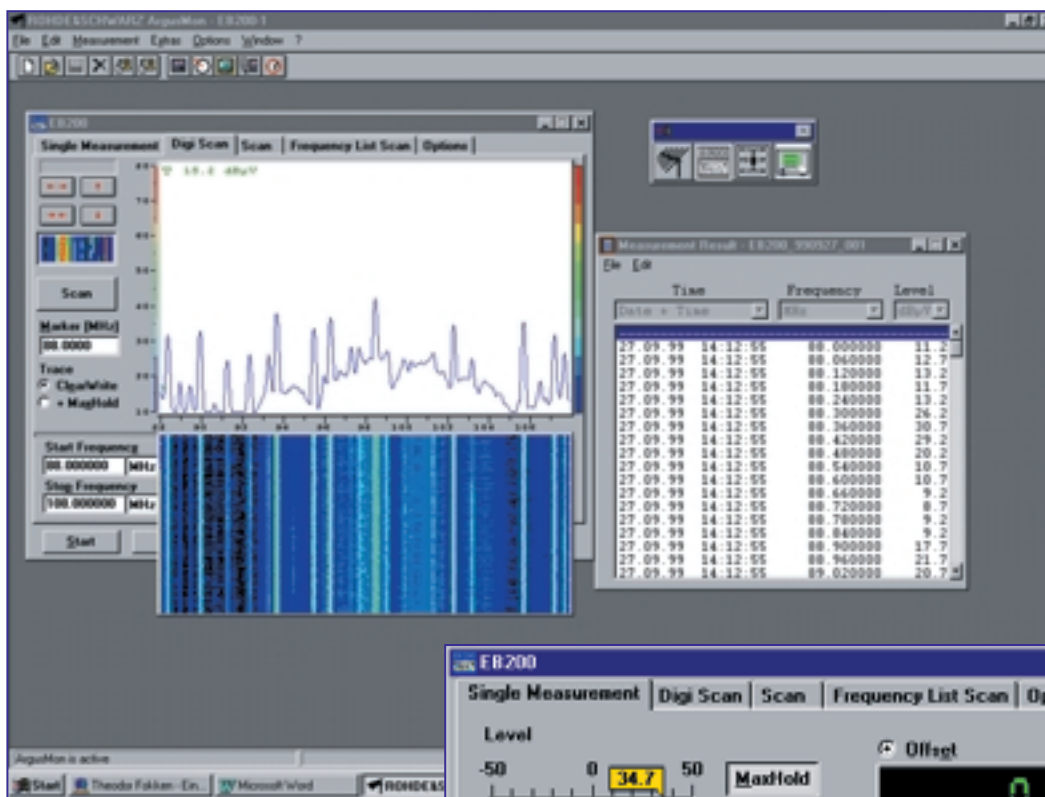

FIG 2 Complete spectrum recordings with date, time, frequency and level can be stored with the "Save" function. About 200 measurements per second can be performed via the LAN interface of EB200

FIG 3 Even single-frequency measurements can be stored and conveniently documented together with all receiver settings

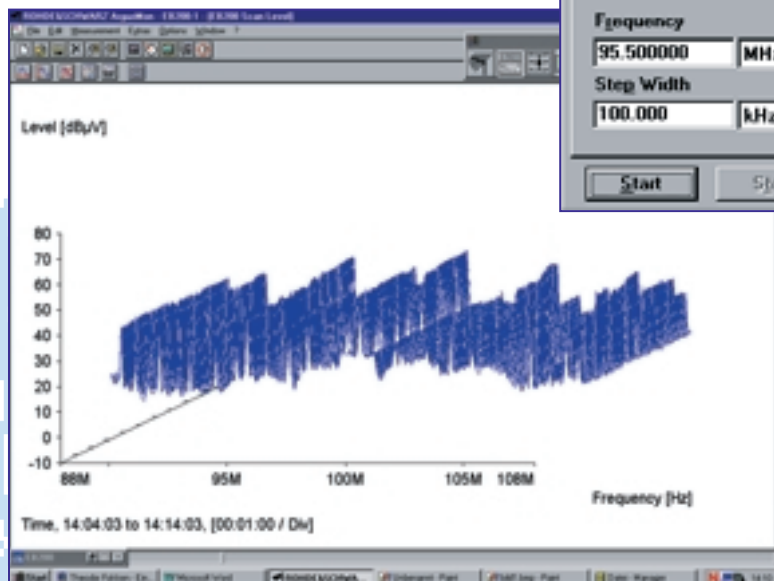
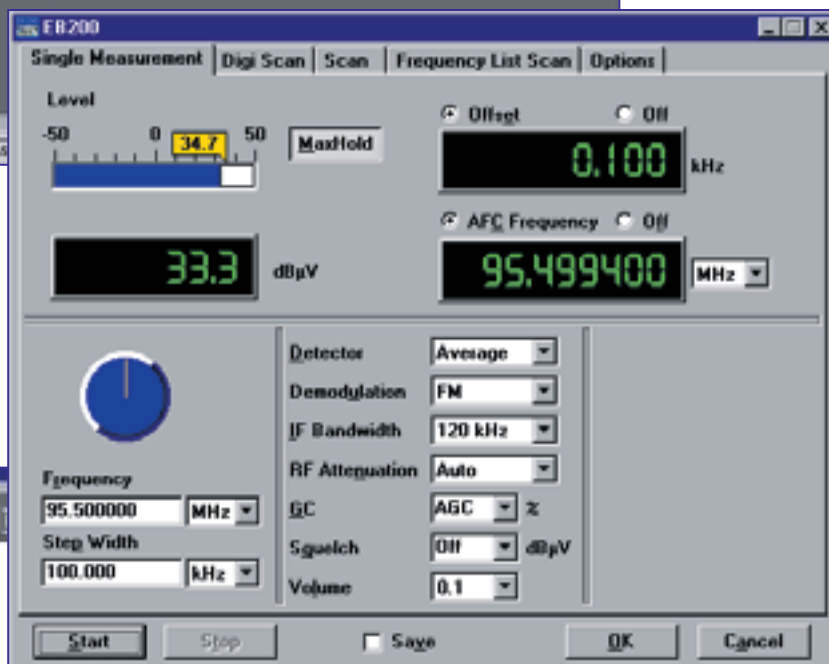

FIG 4 In the normal scan mode with stepwidth definition, EB200 displays the spectrum as Cartesian, 2-D or 3-D waterfall diagram – with and without offset

Although the receivers offer a whole variety of functions, FIGs 2 to 4 show that their operation is still user-friendly and clear. The attractively priced basic ARGUS MON software can be extended for use in systems of any size.

Theodor Fokken

Reader service card 165/05

Test Antenna ULTRALOG HL562

No tiresome changing of antennas: universal and broadband EMC measurements

International EMC standards stipulate measurement of emissions and immunity to interference over increasingly wider frequency bands. The use of narrowband antennas takes considerably more time since each measurement has to be interrupted to change the antennas required. To avoid these costs, which should not be underestimated, test antennas covering a wide frequency range are needed. ULTRALOG HL562 is tailored to meet these requirements. It is suitable for both interference field strength measurements and susceptibility measurements. Thanks to its compact design and low weight it is at the same time easy to handle.

Photo 43317/2



FIG 1
Test Antenna ULTRALOG
HL562 is also available with
tripod

Wide frequency range, yet compact design

Test Antenna ULTRALOG HL562 (FIG 1) is in fact an antenna system: it combines a biconical dipole with a log-periodic antenna. This makes for a wide frequency range from 30 MHz to 3000 MHz, which is covered by the broadband dipole up to about 200 MHz and above this by the log-periodic directional antenna.

Current standards for interference field strength stipulate measurements in the frequency range 30 MHz to 1000 MHz, some US specifications up to 2 GHz and even higher. A CISPR/G resolution concerning ITE (information technology equipment) provides for measurements up to 2.7 GHz. ULTRALOG with its wide specified frequency range is a highly attractive solution as it enables emission measurements to be performed with just one antenna.

For immunity to interference measurements, standards do not define a precise lower frequency limit below 80 MHz. Featuring a lower operating frequency of 30 MHz, ULTRALOG covers the range relevant for practical use. At the request of many customers, the dimensions of the biconical dipoles were reduced to what is physically feasible and meaningful, thus considerably simplifying antenna handling. For frequencies from 600 MHz, the V con-

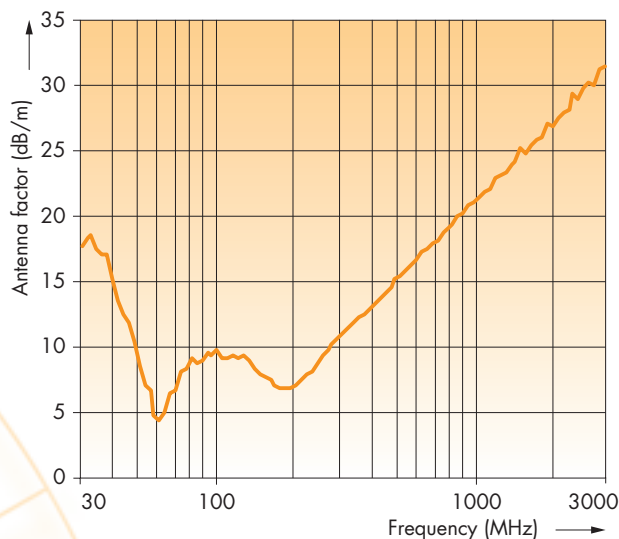

FIG 2 Antenna factor of HL562 in free space (typical values)

figuration of the directional antenna makes for increased gain despite the small dimensions of the antenna (FIG 2). Gain enhancement compensates for the reduction in system sensitivity that would otherwise make itself clearly felt because of the cable attenuation, which increases with frequency (see FIG 2, typical characteristic of antenna factor).

Attractive features make for versatile use

ULTRALOG's wide frequency range and its capability of performing field strength measurements plus immunity measurements at field strengths up to 10 V/m make for highly versatile use of this compact test antenna. But HL562 has further qualities: the V configuration of the dipoles not only results in improved antenna gain but also yields largely rotationally symmetrical and congruent directional patterns in the E plane and the H plane above 200 MHz. This may eliminate the need for a second measurement, which is defined in some test specifications if polarization is not symmetrical.

CISPR 16-1 stipulates polarization isolation of at least 20 dB to keep measurement uncertainties to a minimum (in this case, an error lower than approx. 1 dB is obtained). ULTRALOG complies with this stipulation of course. Products with polarization isolation of only 14 dB have an additional error of 2 dB, which is unacceptable for many measurement tasks.

Another innovative feature of HL562 is its construction. There are no loose dipoles because the complete log-periodic antenna is made of one piece. The longer dipoles are interconnected by means of transverse braces, ensuring high mechanical stability despite the compact and lightweight design.

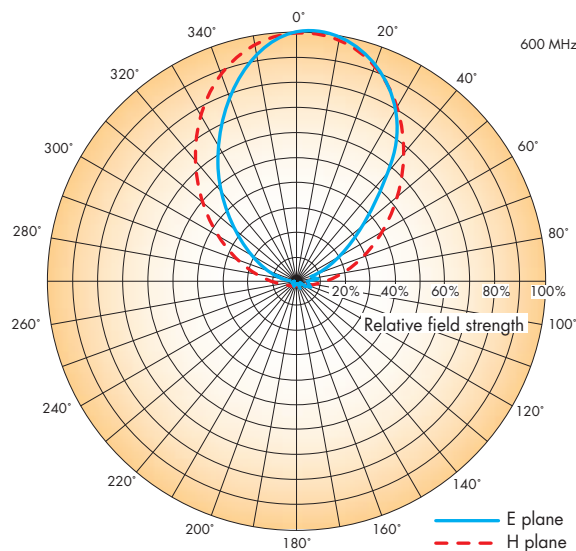

FIG 3 Directional pattern of HL562 (here at 600 MHz) is almost rotationally symmetrical in E and H planes

Calibration of course

ULTRALOG HL562 is factory-calibrated prior to delivery. Calibration is performed to ANSI C63.5 in the frequency range 30 MHz to 150 MHz above conductive plane, and to DIN 45003 in the remaining frequency range in free space. In both cases the three-antenna method is used and a tolerance analysis carried out. Calibration data are supplied with the antenna as hardcopy and on disk to ensure simple transfer of the specific antenna data to the test system.

Klaus Fischer;
Dr Christof Rohner

Condensed data of Test Antenna ULTRALOG HL562

Frequency range	30 MHz to 3000 MHz
Polarization	linear
Cross-polarization suppression	20 dB
Gain	typ. 8 dB

Reader service card 165/06

HF antenna systems for radiomonitoring

Complete coverage tailored to requirements: HF radiomonitoring over any azimuth and distance

Shortwave signal monitoring has lost nothing of its topicality in recent years. Quite the reverse: the security scenario, which has in part radically changed, has made it necessary for many countries to even expand their radiomonitoring activities. Whereas previously signals often had to be monitored only over certain distances or in certain directions, today there is a growing demand for monitoring systems capable of receiving signals from any direction and over any distance. Log-periodic antennas from Rohde & Schwarz and their combination into customized systems master virtually any reception task (FIG 1).

Photo 36608/2



FIG 1 Directional Log-Periodic Antenna HL541 is an ideal choice both for standalone applications and in customized systems for handling difficult reception tasks (see also FIG 4)

Conventional receiving systems often not in keeping with the times

One of the well-known, fundamental laws in HF engineering is that the antenna or antenna system is an element that decisively determines system

characteristics. A vital prerequisite for antennas in HF radiomonitoring is that they must be broadband, i.e. have constant technical characteristics over a wide frequency range. In conventional HF radiomonitoring systems, this was frequently implemented by means of Beverage or rhombic antennas that, if appropriately configured, generate frequency-dependent radiation patterns strongly directional in azimuth and elevation. This, however, allows only a narrow region to be covered or, when several antennas of this type are used, a few "islands". For state-of-the-art radiomonitoring systems, this limitation can hardly be accepted any more taking into account today's spectrum of tasks [1].

Tailoring antennas to a given reception task

Besides the above-named demand for broadband characteristics, today's antennas have to meet the demand for complete coverage of all distances. This is fulfilled ideally by horizontally polarized log-periodic antennas, whose vertical pattern, on top of this, can be tailored to a task by varying height above ground. **Log-Periodic Antenna AK410A3** from Rohde & Schwarz provides complete coverage of the HF range from 1.5 MHz to 30 MHz and has a half-power beamwidth of approximately 70°. By using masts of different height, thus varying the distance of the radiators from ground,

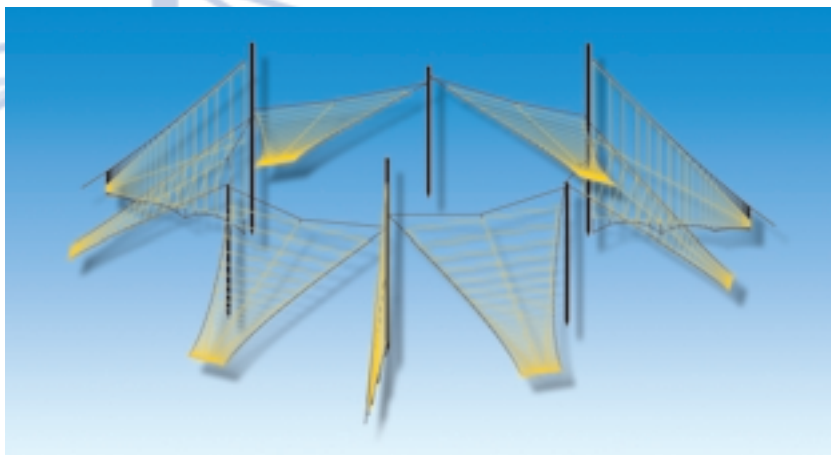

FIG 2 Antenna System AK610A3 (LP star) covers all directions and ranges without a gap

signals incident at steep angles and those incident at flat angles can be received equally well. The antenna thus offers optimal reception for emissions over short, medium and global distances alike. Alternatively, to handle special tasks, the vertical pattern can be shaped to focus on defined target areas.

The use of a horizontally polarized antenna is expedient, since HF signals reflected by the ionosphere and thus elliptically polarized generally contain more horizontally than vertically polarized components. Nevertheless, such signals are subject to variations with time, depending, among other factors, on the state of the ionospheric layers. It cannot be ruled out that at times vertically polarized components will dominate at the site of reception, especially if signals from distant transmitters are received. It is then best to extend the installation by vertically polarized antennas to avert periodic sharp drops in receive level. **Log-Periodic Antenna AK210A3** is the vertically polarized counterpart of AK410A3 and covers the same frequency range. Its radiators are in the form of dipoles, resulting in high gain and extremely low sensitivity to effects from the ground.

This does away with the need for a ground network.

Thanks to their optimized design, both antennas feature good matching and almost frequency-independent directional patterns, directivity between 10 dB and 12 dB and efficiency greater than 90 % over the entire frequency range.

Omnidirectional reception at all angles with an LP star

Due to the relatively large half-power beamwidth of approx. 70° of the horizontally polarized Directional Antennas AK410A3, only six of these antennas are needed to cover all of 360° in azimuth. This produces a horizontal radiation pattern with an uncircularity of only about 2.5 dB. Analogously, three vertically polarized Antennas AK210A3 with 120° half-power beamwidth each cover all elevation angles with an uncircularity of max. 2 dB. **Antenna System AK610A3** combines the two configurations: the vertical antennas are installed in the gaps between two horizontally polarized log-periodic antennas, which ensures decoupling between the individual

antennas (FIG 2). This arrangement is often called an LP star (LP = log-periodic) after its configuration. It covers the entire azimuth range and – if appropriately designed – also all distances (FIG 3). Compared to systems offering similar radiation characteristics and decoupling, AK610A3 is notable for its small space requirement and as a result relatively low price [3], which is also due to the fact that only a few masts are required.

FIG 3 Azimuth patterns of Antenna System AK610A3 with virtually perfect omnidirectional characteristics

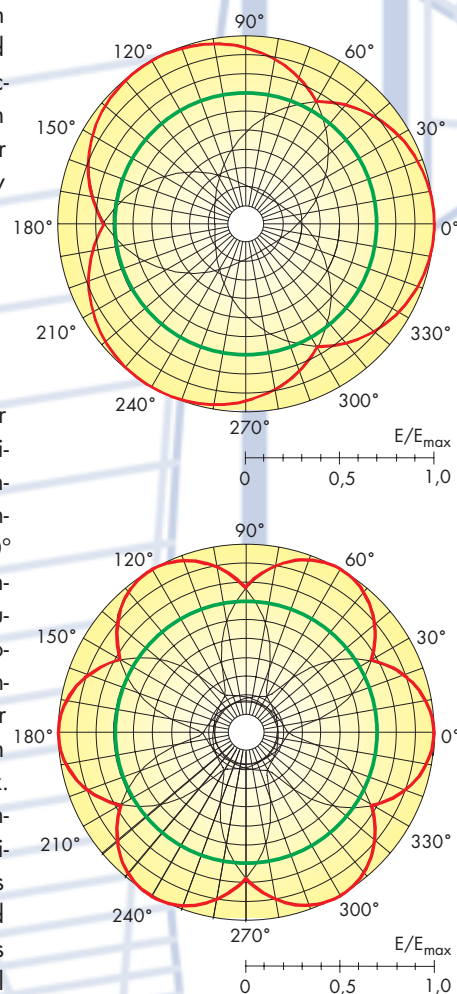

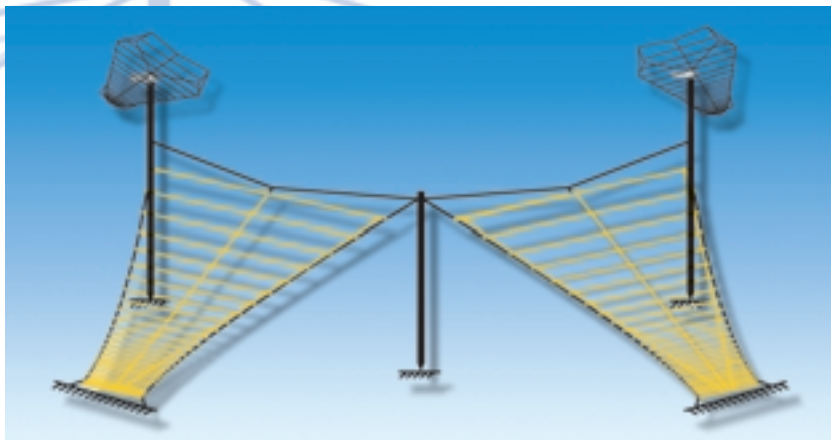

FIG 4a Combination of two fixed Antennas AK410A3 with two rotatable Log-Periodic Antennas HL451

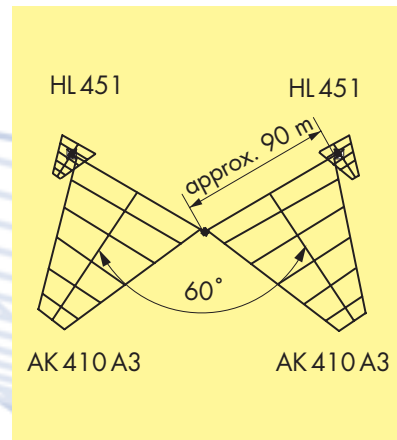

FIG 4b Top view of system shown on the left

Antenna systems made to measure

Where installing System AK610A3 would not seem appropriate because it does not suit the task on hand, space is at a premium or limited budget is available, other configurations can be realized. In particular, parts of System AK410A3 can be combined with one or several rotatable, Log-Periodic Antennas HL451 (FIG 1) [3]. In such a configuration, one or more sectors are per-

manently monitored by means of fixed directional antennas, whereas HL451 can be turned to any desired direction (FIG 4). It is obvious that this approach also contributes to saving space, masts and costs. AK210A3, AK410A3 and HL451 are thus the building blocks with which HF radiomonitoring systems tailor-made for practically any requirements can be designed.

Ludwig Nielsen;
Dr Christof Rohner

Condensed data of Log-Periodic Antenna AK410A3

Frequency range	1.5 MHz to 30 MHz
Polarization	linear, horizontal
Gain	≥8 dB

Condensed data of Log-Periodic Antenna AK210A3

Frequency range	1.5 MHz to 30 MHz
Polarization	linear, vertical
Gain	≥8 dB

Condensed data of Directional Antenna HL451

Frequency range, transmission	5 MHz to 30 MHz
Frequency range, reception	2 MHz to 30 MHz
Polarization	linear, horizontal
Gain	9 dB to 12.5 dB (on 30 m mast)

Reader service card 165/07

REFERENCES

- [1] Stark, Axel: New antenna system for the communications intelligence regiment 940 of the German Armed Forces. MIL NEWS from Rohde & Schwarz (1998) No. 1, pp 13-14
- [2] Friede, Klaus: Antenna System AK610 for HF radiomonitoring. News from Rohde & Schwarz (1998) No. 159, pp 28-29
- [3] Nielsen, Ludwig: Compact Rotatable Log-Periodic Antenna AK451 for 5 MHz to 30 MHz. News from Rohde & Schwarz (1987) No. 118, pp 35-36

W-CDMA Rx/Tx Test System TS8950A

Startup of 3G air interface simulator

3G is well on its way. Rohde & Schwarz is accompanying the rapid development with a modular, open test system that responds flexibly to the still changing specifications of the standards. Test System TS8950A (FIG 1) is a first step towards 3G Air Interface Simulator TS8950, permitting the creation of customized W-CDMA transmitter/receiver test scenarios.

Photo 43 413/1



What is needed: test solutions to grow with requirements

Wideband CDMA technologies prevailed as standards for third-generation mobile radio (3G). The 3GPP body is strongly oriented towards European and Japanese needs and supports the two W-CDMA branches, the DS (direct spread) and TDD (time division duplex) mode. In the USA, preference is given to further development of cdmaONE into CDMA2000 with 1x, 3x and MC (multicarrier) modes. The Operators Harmonization Group (OHG) decided that 3G terminals should also support the MC mode of CDMA2000 beside the 3GPP standard to allow worldwide roaming. This makes terminals even more complex – if only because of the different chip rates. Demands are getting louder for universal test solutions that grow along with requirements.

FIG 1 Rohde & Schwarz starts into the 3G test world with Test System TS8950A. As standardization advances, the system will be upgraded to 3G Air Interface Simulator TS8950

Early on the market and already ripe

The future 3G Air Interface Simulator TS8950 from Rohde&Schwarz is a modular test platform for mobile radios and base stations that meets requirements of third-generation mobile radio. The start has already been made, the core standard (TS25.101 and TS25.104) specified by 3GPP (3rd generation partnership project) is sufficiently advanced in the DS mode of W-CDMA for Rohde&Schwarz to present the first configuration level in the form of Rx/Tx Test System TS8950A. The system features excellent measurement accuracy thanks to high-performance components like

- Signal Analyzer FSIQ,
- Vector Signal Generator SMIQ,
- I/Q Modulation Generator AMIQ and
- RF Signal Switching and Conditioning Unit SSCU developed for 3G tests.

The flexible software concept ensures conformity of the system with the standards despite the presently still unstable test specifications (TS25.141 or

TS34.121). As already indicated in [*], TS8950A uses individually parameterizable test methods instead of rigid test cases that can be combined into any desired test scenario.

Open software architecture

The **system software** of TS8950A is organized in clearly defined layers analogously to the OSI reference model (FIG 2). The layers are implemented in the form of independent processes that communicate by means of fixed data primitives on defined interfaces. The system software management entity (SSME) initializes these processes and controls data flow. At the lowest level (interface layer) the physical interfaces for system component control are addressed. The database of the layer above (device layer) contains all relevant information on the instruments contained in the system. If future test requirements cannot be met with the available components, the instrument pool and thus system functionality can be modified or extended via this layer without affecting overall architecture.

The **test methods** – eg BER measurements – are stored in the next highest layer (system layer) and form the smallest unit of a test script. Test sequences at the application layer are obtained by combining test methods and initialization (eg parameters of mobile radio cell) with settings of the test environment (eg fading and interference conditions). If such a test sequence meets the requirements of a specific mobile radio standard, one speaks of a test case, eg a blocking test case. At the application level, the tests are organized in groups that are relevant for future conformance test scenarios.

Convenient access to any application range

Because of the ongoing development of the test specifications, defined test cases are not yet available. The test system therefore provides different types of access to the individual layers of the system software for generating customized test sequences. Access is either in the form of a dialog via the graphical user interface AUP (advanced user panel) or on the application programming interfaces API.

At the **device level**, a separate dialog is available for each system component that can be remotely controlled via a defined interface. The instrument dialogs are tailored to 3G requirements and organized in logical blocks for emulating mobile radios, base stations and services. Entries can also be made for individual device command strings, eg GPIB commands. Every instrument dialog comprises a macro recorder/player for recording and replay of specific device settings (macros).

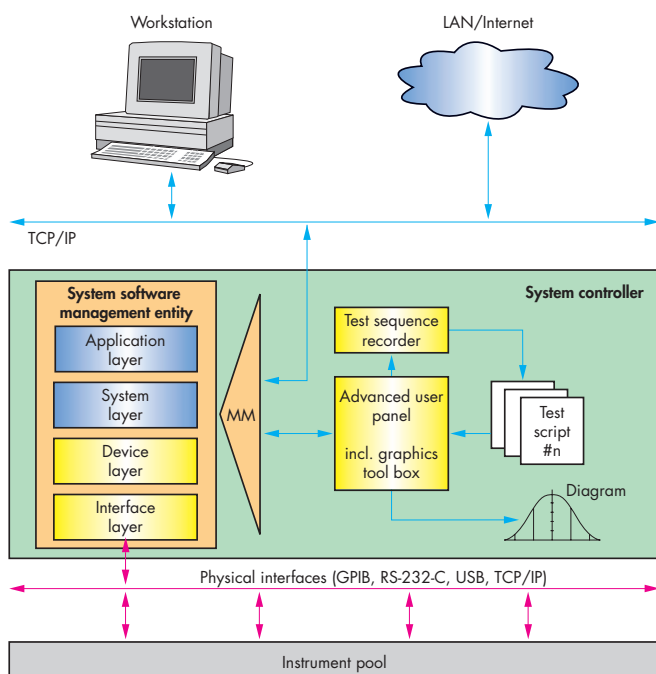

FIG 2 Functional software architecture of TS8950A

Rx/Tx measurements and result analysis at the **system level** are also dialog-controlled. The AUP provides a defined script for each measurement which can be edited and extended. This plain command file (PCF) allows direct addressing of the device layer and thus direct access to the individ-



FIG 3
Advanced user
panel of Tx test
dialog (example)

ual instruments including the switching and conditioning unit. With the aid of a macro sequence manager, individual macros can be combined into sequences permitting complex measurements.

User management ensures that simultaneous access by different users does not cause a configuration conflict. Of course this restriction does not apply to simultaneous access of test results for analysis. A logging mechanism stores all the settings made.

The AUP also supports **service dialogs** that perform fully automatic RF path compensation, for instance, or simplify system maintenance and configuration by selftest and diagnostic routines of individual components. The RF compensation routines of Signal Switching and Conditioning Unit SSCU need not follow fixed test-case patterns but can be started in compliance with user specifications.

Reaching the target in three steps

The modular concept of this test system paves a future-proof path in the evolution of 3G tests: starting from basic Rx/Tx test scenarios through performance tests with L1 signalling (TS8950B) to full conformance tests with complete layer 1 to layer 3 signalling (TS8950C). In brief, 3G Air Interface Simulator TS8950 is on the best way to becoming the platform for precompliance tests of third-generation mobile radios and base stations.

Holger Jauch

Reader service card 165/08

Available and planned configuration levels of TS8950

The application range of the presently available **TS8950A** system covers basic Rx/Tx tests without signalling. This includes the following measurements at the transmitter end:

- frequency stability,
- occupied bandwidth,
- maximum output power,
- adjacent-channel leakage power,
- spurious emissions,
- transmitter intermodulation,
- transmitter on/off ratio,
- modulation accuracy, (EVM, rho factor),
- code domain power analysis (offline).

The following can be measured at the receiver end:

- sensitivity,
- selectivity (eg adjacent-channel selectivity, blocking).

The subsequent model **TS8950B** extends the application spectrum especially by performance tests requiring coding/decoding. The transmitter measurements of this system include:

- code domain power analysis,
- output power control (inner loop, outer loop).

Additional measurements at the receiver end:

- spurious emission,
- receiver intermodulation,
- spurious response and blocking,
- receiver dynamic range.

Model **TS8950C** finally performs all conformance measurements including complete layer 1 to layer 3 signalling.

REFERENCES

- [*] Jauch, Holger: Third-generation mobile radio – universal test concepts pave the way. News from Rohde & Schwarz (1999) No. 164, pp 29–31

MONLOC software GSM data link networks direction finders

MONLOC software combines digital monitoring direction finders of the type DDF0xM into extensive radiolocation systems that can be used for regional through nationwide spectrum monitoring, for security purposes as well as in military missions. A large variety of interfaces is available for this kind of application. A new possibility is the use of GSM links for data exchange. And in this way mobile direction finders can also be integrated into versatile DF networks

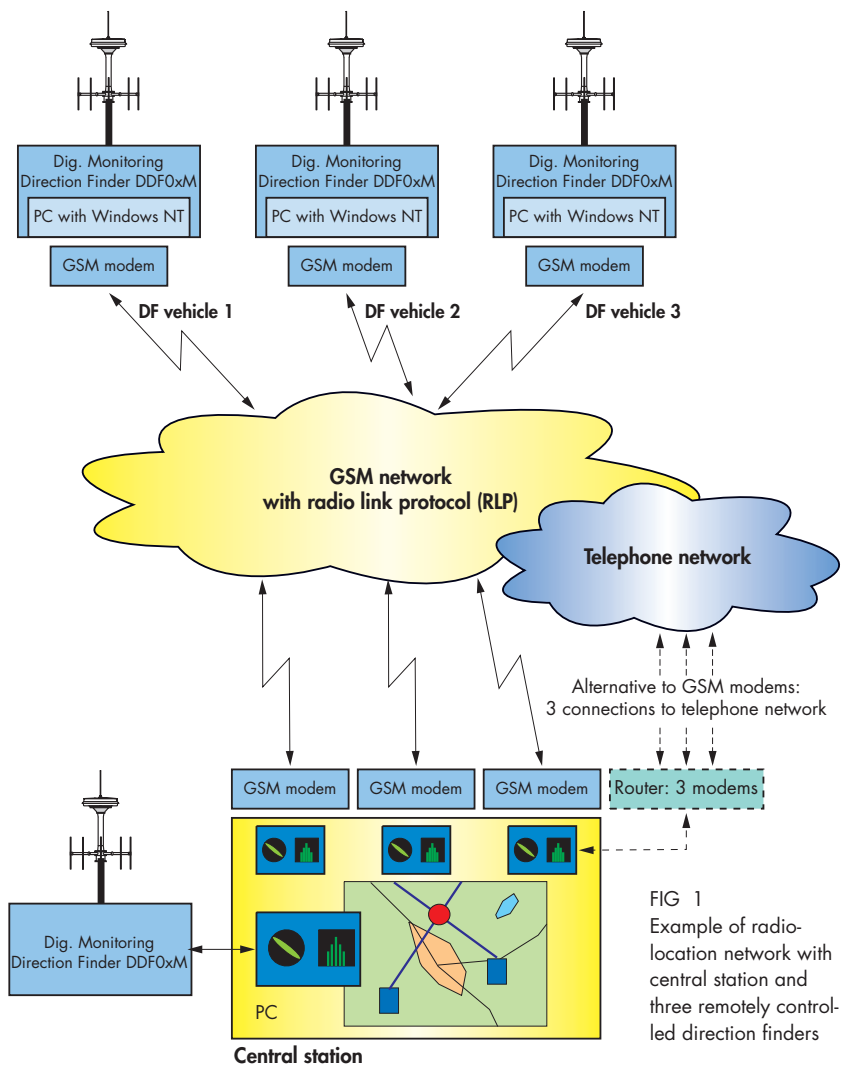

FIG 1 Example of radiolocation network with central station and three remotely controlled direction finders

From standalone to system

Digital Direction Finders DDF0xM from Rohde & Schwarz are able to take bearings of conventional signals as well as short-duration signals and broadband emissions in the frequency range

from 300 kHz to 3 GHz [*]. With the aid of MONLOC (derived from "location system for monitoring direction finders") software, such monitoring direction finders can be combined into a radiolocation system and remotely controlled from a central station.

MONLOC displays the user interfaces of the remote, digital monitoring direction finders as well as digital maps on a PC in the central station for remote control. This PC must be equipped with data links to the direction finders, a variety of interfaces being available for the purpose (see box). Data links working through GSM modems is a new possibility. The links to the individual direction finders may also be different. Some of the direction finders may be stationary with conventional data lines and some of them mobile (eg in vehicles or transit cases) with GSM links. This allows versatile DF networks to be configured (FIG 1).

The central station is connected to the direction finders either through GSM modems or by routers and the regular telephone network. The relatively low transmission rate of 9600 bit/s is efficiently used so that even the IF spectrum or – using special data compression – audio information can be transmitted.

Convenient central control

PC operation in the central station is both simple and straightforward. From a list the operator chooses the DF stations best situated for determining the particular signals. The data links to the selected direction finders are established automatically. Three direction finders should be activated, if possible, for really reliable location results.

The user interfaces (FIG 2) of all direction finders can be simultaneously displayed on the screen in the central station. Activating one of the interfaces makes the associated direction finder the master. All entries are automatically transmitted to the other direction finders and executed. By successively

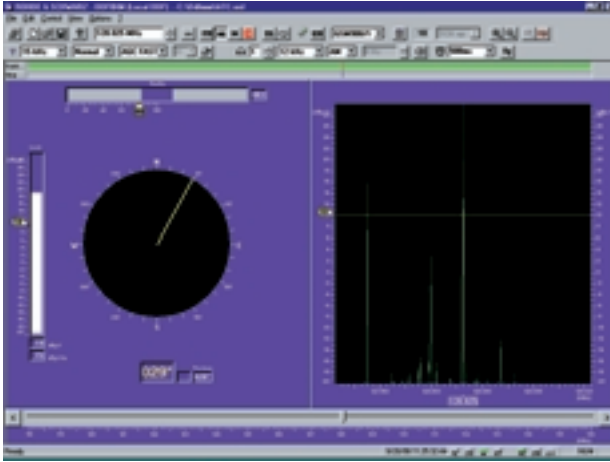

FIG 2
User interface of
DDF0xM direction
finder

activating the individual user interfaces, the audio information of the direction finders can be compared to ensure that all stations take bearings of the same emitter with the same setting parameters.

Master with two operating modes

In searching for new or unknown signals, one of the direction finders is always the master. Two operating modes are available: automatic search in a frequency band or frequency list for signals exceeding a preset level (search mode), or manual selection of

a signal from a broadband spectrum display (scan mode). Direction finders can also be set manually to a fixed frequency.

In **search mode** the master direction finder searches for emissions in user-definable frequency bands or lists. As soon as it detects a signal above a defined threshold, the software automatically sets all other direction finders to this same frequency.

Scan mode is recommended for direction finders connected via a fast data line (eg ISDN with 64 kbit/s). The direction finder displays the spectrum of a defined frequency band. After manual

selection of a frequency from this spectrum, all activated direction finders take bearings of the same signal.

Comfortable results display and management

MONLOC is provided with the MapView software module from Rohde & Schwarz, which displays digital maps and marks transmitter locations by coloured circles (FIG 3). The DF results are also stored in a logbook on hard disk, so unattended operation with later evaluation of results is another possibility.

Frequency and position of a transmitter can be saved together with special features (eg licensed or non-licensed) in a signal library under a specific name. When an emitter is detected that is already contained in the signal library, the software automatically labels its position in the map with the associated name. A postevaluation option allows stored results to be recalled and displayed as the "track" of a mobile source of signals for instance.

Rudolf Reimann

Reader service card 165/09

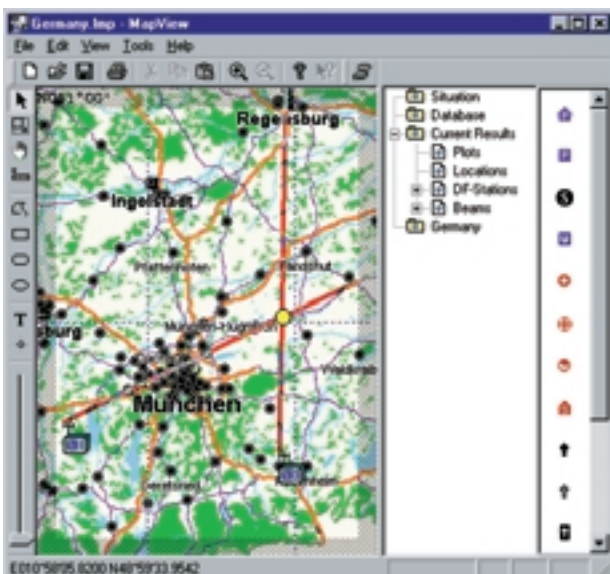

FIG 3
Digital map with DF
sites, DF beams and
location result

Possible data links PC – direction finder

Protocol: TCP/IP via

- RS-232-C
- LAN
- ISDN
- PSTN
- microwave
- GSM

REFERENCES

- [*] Demmel, Franz; Unsel, Ulrich; Dr Schmen- gler, Eckhard: Digital Monitoring Direction Finders DDF0xM – State-of-the art direction finding from HF to UHF. News from Rohde & Schwarz (1996) No. 150, pp 22–25

Microwave Signal Generator SMR

Testing receivers for satellite telemetry signals

Remotely controlled receivers in satellites play an important role: they receive telemetry signals for guiding a satellite to the desired position. Satellite operators therefore require highly accurate figures for noise threshold from the receiver manufacturer because a reliable, remotely controlled radio link is only possible if the receiver's limit sensitivity is as good as -130 dBm. Microwave Signal Generators SMR [1] offer the best prerequisites for measuring this parameter.

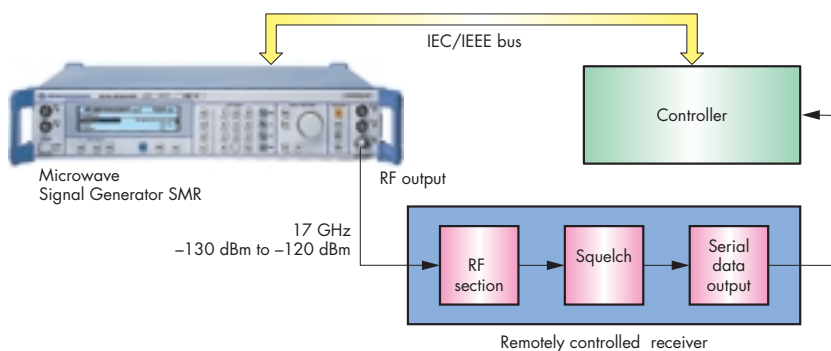

FIG Measurement of squelch response threshold

Modern communication and information satellites have names like Kopernikus or more exotic sounding ones such as Hot Bird. They supply us with all types of radio and TV programs, offer a large number of telephone channels and permit fast Internet access.

The subject of this article is not complex transponder technology but the more *invisible* components onboard satellites, eg small remotely controlled receivers that are operated typically at 17 GHz.

The word invisible by no means implies unimportant, since the perfect functioning of such receivers is decisive in bringing a costly satellite to its planned orbital position. A launcher rocket takes the satellite part of the way towards its final position. On reaching the intended maximum altitude, the rocket ejects the satellite, which then continues to its planned position under its own momentum. Since ejection is anything but soft, the satellite's position is initially

not stable. During this stage, therefore, directional antennas cannot be lined up to the ground station for the purpose of steering. So one is compelled to use omnidirectional antennas, whose gain, however, is far below that of directional antennas. With poor antennas of this kind, a reliable remotely controlled link can only be maintained if the receiver shows a limit sensitivity of -130 dBm.

Luckily a data transfer rate of 50 to 100 bit/s is sufficient for transmission of the remote commands, which necessitates only a narrow receiver bandwidth and thus the problem of noise can be restrained. Yet there must be a squelch in the receiver, whose function is to prevent incorrect response from the receiver if the signal from the ground station becomes too weak because of the satellite's position or the signal simply drops out. Standard specifications of satellite operators stipulate that the squelch should respond at receive levels of <-124 dBm, and the

receiver manufacturer is required to verify measurement of this threshold value to an accuracy of $<\pm 2.5$ dB.

The test setup shown (FIG) provides for this verification. Microwave Signal Generator SMR together with Attenuator Option SMR-B20 is ideal for this application because:

- the smallest settable level is -130 dBm,
- level accuracy at -124 dBm is better than ± 2 dB,
- RFI is extremely low due to the excellent shielding.

The measurement procedure is quite simple. SMR is set to the receive frequency, which is 17 GHz in this case. The RF level is then continuously reduced until the squelch responds. The output level of SMR can be varied in 0.01 dB steps so that the response threshold can be determined precisely. The specified level accuracy is guaranteed in the temperature range between $+18^\circ\text{C}$ and $+28^\circ\text{C}$.

If even more precise measurements are required, this is no problem either. At 17 GHz and a level of -124 dBm measurement accuracy can be increased to $\leq \pm 0.8$ dB if SMR is calibrated in a special test setup [2]. The following measurement equipment is then required in addition, one of each unit:

- Spectrum Analyzer FSEM with option FSE-B22
- Preamplifier AFS5-00101800-23-10P-5 (manufacturer: MITEQ)
- Dual-Channel Power Meter NRVD with Power Sensor NRV-Z1

The described, remotely controlled receivers are normally built with only simple shielding or with none at all to reduce the receiver's weight for use in satellites. This is acceptable for the

reason that there are no interfering sources in space that could disturb the receiver. Thanks to the low RF emission of SMR, satellite receivers as open DUTs can be measured without having to resort to shielding boxes or similar.

Wilhelm Kraemer

REFERENCES

- [1] Kraemer, Wilhelm: Microwave Signal Generator SMR – 40 GHz per click. News from Rohde & Schwarz (1999) No. 162, pp 4–6
- [2] Minihold, Roland: RF Level Test System +20 dBm to -130 dBm. Application Note from Rohde & Schwarz (1999) No. 11/99 – 1MA21_1E

Reader service card 165/10

Signal generators – from baseband to microwave

The mere title "Signal Generators" of the new CD-ROM from Rohde & Schwarz, subtitled "From baseband to microwave", does not betray that this is a both comprehensive and attractively designed compendium of the signal generation product range. When you start the German/English disk, you see some startup animation and then a clearly structured main menu offering a large number of choices. You can select uses, signal types and frequency ranges, and the matching equipment will be displayed.

Once you select a particular generator, a view of the instrument appears and a menu for calling up type information.

This includes a complete manual, an overview of options as well as the data sheet in PDF format. Application notes and demo software are also contained for a large number of generators.

A special function is provided under "Operation": the instrument display is shown and its functions are simulated. This is done by an animated sequence demonstrating the most important functions and operation of the generator.

Key symbols for easy navigation through the disk – resembling the keys on CD players – are visible all

the time. "History" shows a list of the pages selected so far, allowing you to refer back fast. Further permanent keys offer a direct link to Rohde & Schwarz's Internet homepage and an option for sending an e-mail to Rohde & Schwarz. The wealth of information offered on the CD is rounded off by numerous animated sequences.

Stefan Böttinger

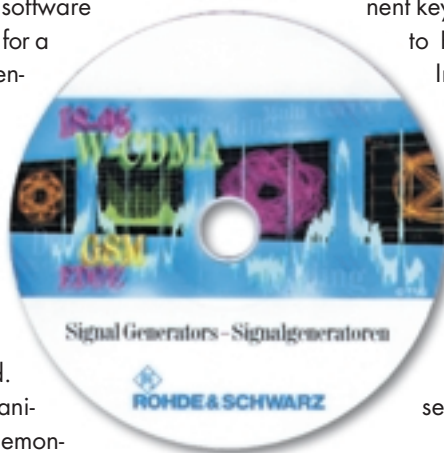

* Available free of charge from every Rohde & Schwarz representative

NetHawk™ Analysis and Simulation Software

Wired measurements for mobile radio systems

NetHawk™ is a PC-based family of protocol analyzers and simulators for modern communication networks. Whereas Radio Communication Testers CMD and CMU from Rohde & Schwarz focus on measurements on the air interface, NetHawk™ was specially designed for fixed-network measurements at the interfaces to national and international communication systems. Apart from the GSM application described, NetHawk™ is also available with software for analysis and simulation of SS7, ISDN and V.5 protocols.



FIG 1 NetHawk™ also runs on laptops: ideal for mobile use

NetHawk™ = PC card + software

NetHawk™ products consist of a PC card (or N2 card for laptops, FIG 1) with an adapter to the fixed network, and associated measurement software running under Windows 98™ on laptops or Windows NT™ on desktop PCs. The plug-in card for desktop PCs with a fast PCI bus allows twice as many lines and channels to be monitored simultaneously as the laptop card.

The measurement software performs analysis and simulation on the interfaces commonly used in modern transmission systems such as

- GSM
- GPRS
- UMTS
- ISDN
- WLL

and can handle all interfaces (FIG 2):

- with E1 and T1
- V.5.1 and V.5.2 access networks
- SS7 fixed network
- GSM mobile network

NetHawk™ is a product of the Finnish company X-Net, a specialist in protocol analysis for more than seven years with over 50 employees. Rohde & Schwarz Engineering and Sales (RSE), a subsidiary of Rohde & Schwarz, has acquired non-exclusive sales rights for NetHawk™ products.

Example: BTS tester for GSM

A typical application of NetHawk™ is mobile testing of BTSs (base transceiver stations) in GSM mobile-radio networks (FIGs 3 and 4). Here NetHawk™ is configured with one or two N2 cards as well as software for simulating the A_{bis} interface and GSM analysis software. Two of the small and lightweight N2 cards can be operated in a laptop with cardbus type II interface. This allows simultaneous analysis of 16 channels (time slots) of two 2 Mbit/s transmission links.

With hardware requirements thus reduced to a minimum, NetHawk™ is the ideal tool for installation teams and mobile task forces. Difficult terrain along GSM-r (rail) routes, base stations installed on towers and roofs and thus difficult to access, or any problems on crossing borders with a large pool of equipment – all this is no longer an issue with NetHawk™.

The user interface and sequence of operations of the GSM analyzer are the same as with other protocols. At the beginning of a measurement, the occupation of the individual channels is determined with the scanner function to find the signalling channel, for example. The selected channels can then be activated for analysis. In the "Layer Details" window, protocol parameters can be selected and assigned different colours for display. The comprehensive "Call Trace" and "Traps" library offers a large number of command sets to filter specific protocol details and, among other things, store protocols with pre- and posttrigger and complete setups.

NetHawk™ BTS testers cannot directly measure signals between a base station and mobile station, but they acoustically check speech quality by means

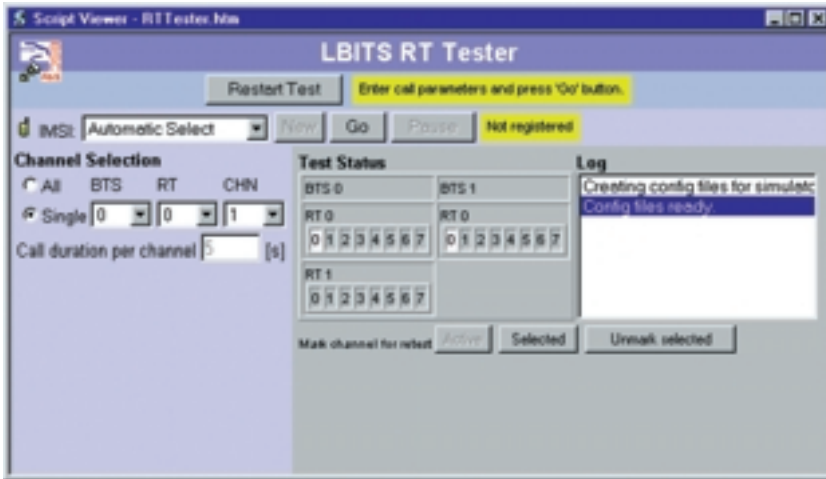

FIG 3 Input window for automatic test sequence

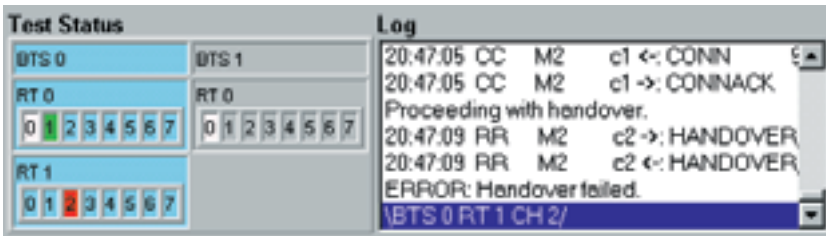

FIG 4 Channels are highlighted in colours depending on test result

of a sound card installed in the laptop. In addition, RxLev and RxQual are graphically displayed in realtime – two parameters that characterize RF transmission.

NetHawk™ BTS testers are used worldwide for installing and monitoring base stations. The specific software needed for configuring and initializing a given base station is integrated in the

BTS tester in each case. Specialists at BTS manufacturing plants can define manual or automatic test routines for quality checking on all GSM channels. In this way, results and quality statistics are obtained that are comparable worldwide. Technicians on site only have to take care of the results produced by the test routines. Should intricate problems arise, the test report together with the stored configuration can be e-mailed to specialists at the central station for offline analysis by the same (licence-free) software.

Ready for UMTS

Mobile phones will soon be capable of transmitting pure data blocks at higher bit rates. The new GPRS (general packet radio services) method transmits data in packets at larger bandwidths. NetHawk™ already offers testing capability for the new A_{bis} , Gb, Gp, Gi and Gn interfaces. NetHawk™ will also be capable of analyzing the UMTS (universal mobile telecommunication service) protocols at the ATM interface (E1 or 155 Mbit/s) as well as the IP (Internet protocol) of third-generation mobile radio.

Wolfgang Krall

FIG 2 NetHawk™ is extremely versatile in its applications

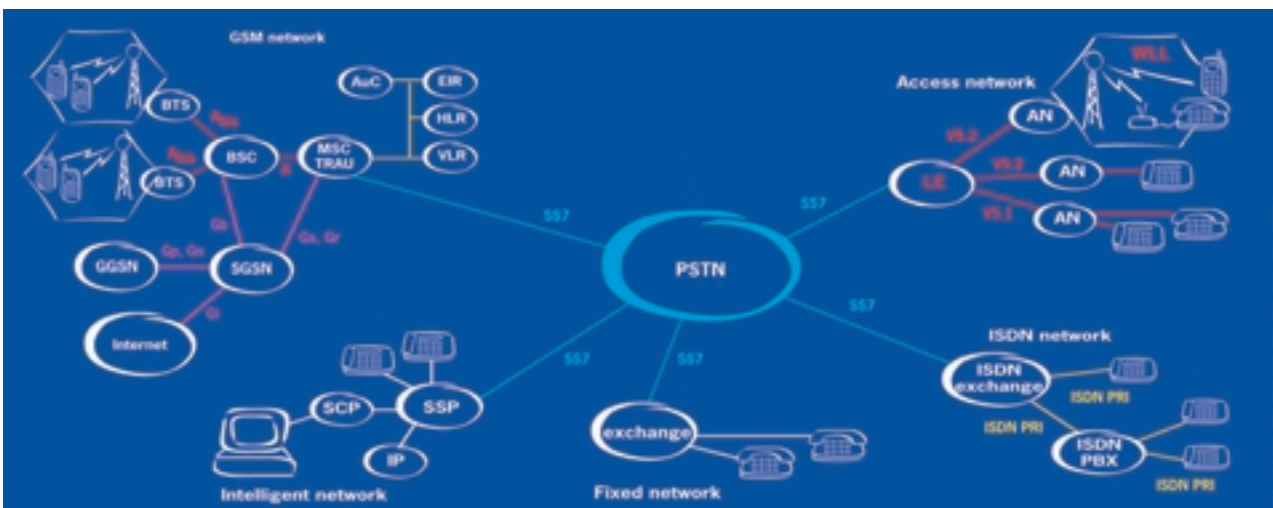

Reader service card 165/11

Key position in IT security: more competence for SIT

SIT, Gesellschaft für Systeme der Informationstechnik mbH, which has been part of the Rohde & Schwarz group of companies since 1991, provides solutions for security in information technology. Focal activities are development of crypto products and systems for the protection of information in modern data processing and communication systems as well as consulting and IT security analysis for commercial enterprises and government authorities. SIT has taken over the department for information security products of Bosch Telecom in Stuttgart. This stock-up of person-competence, enabling the comprehensive spectrum of IT security solutions.

20 billion DM annually. A significant part of this is certainly due to unauthorized access to information through modern communication media.

Complete solutions for IT security

As one of the leading European companies in the field of commu-

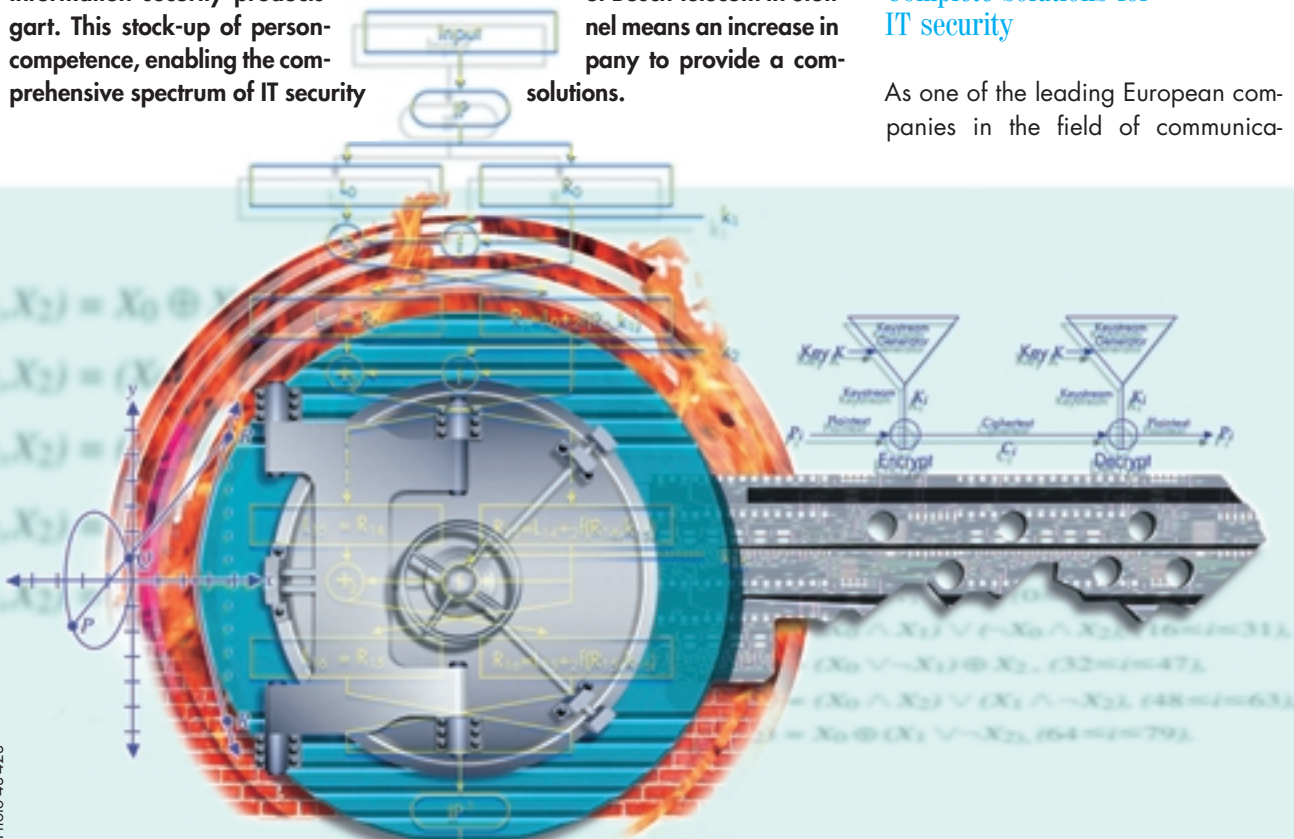

Photo 43 423

Concentrated competence from a single source

With all the new specialists, SIT now has about 60 employees, more than two thirds of them in development. This concentration of mathematicians, physicists, cryptologists, information scientists as well as hardware and software design engineers for communications and information security in one company is rare in the industrial landscape of Germany and Europe. SIT's many years of experience in the design, development and analysis of cryptographic systems is joined by excellent expertise in the implementation of professional,

high-level security encryption equipment and management systems.

This competence is needed more than ever. All trend forecasts for future economic development emphasize the growing importance of the "raw material" information as a resource in national and international economic systems. The dependency of economic systems on the availability, integrity, confidentiality and liability of information increases to the same degree. The latest expert estimates reckon that the damage caused in Germany by economic espionage amounts to approx.

tions, Rohde & Schwarz feels a special responsibility for satisfying demands for high-quality and professional solutions to ensure security of information and communications. The R&S subsidiary SIT has all the capabilities for this challenge. SIT is able to solve fundamental mathematical-cryptologic problems and develops complex hardware and software configurations for crypto systems and equipment. Takeover of the former Bosch product department, which is domiciled in Backnang, complements SIT's fields of activities extremely well, so that a comprehensive choice of IT security solutions can now be offered:

- Design of concepts to safeguard communication networks
- Preparation of specifications for security systems
- Development of high-grade equipment for voice and data encryption
- Terminal equipment for single-channel encryption
- High-speed encryption
- Security management systems
- Integration of crypto systems into communications networks
- Implementation of security-relevant functions and crypto algorithms –

range of equipment for diverse applications that also meets the specific requirements of government authorities and the military. Top security standards can now be complied with including national validation for all security classes as well as NATO (SECAN) validation. Crypto products from SIT are suitable for use in aircraft, land-mobile and stationary communication systems as well as in office environments. SIT is concentrating increasingly on dual-use products, as these enable the commercial world to profit much more than in the past from the kind of developments that meet high-level

more and more in importance (eg trust center). Only very few companies are able to satisfy this kind of requirement. As a reference, SIT can produce a key management system that has been operating stably and failsafe for quite some time.

Computer-aided tools and procedures in line with formal models like the V model or MIL standards are needed for the development of products featuring the described capabilities. Participation of SIT experts in bodies concerned with the further development and standardization of methods and

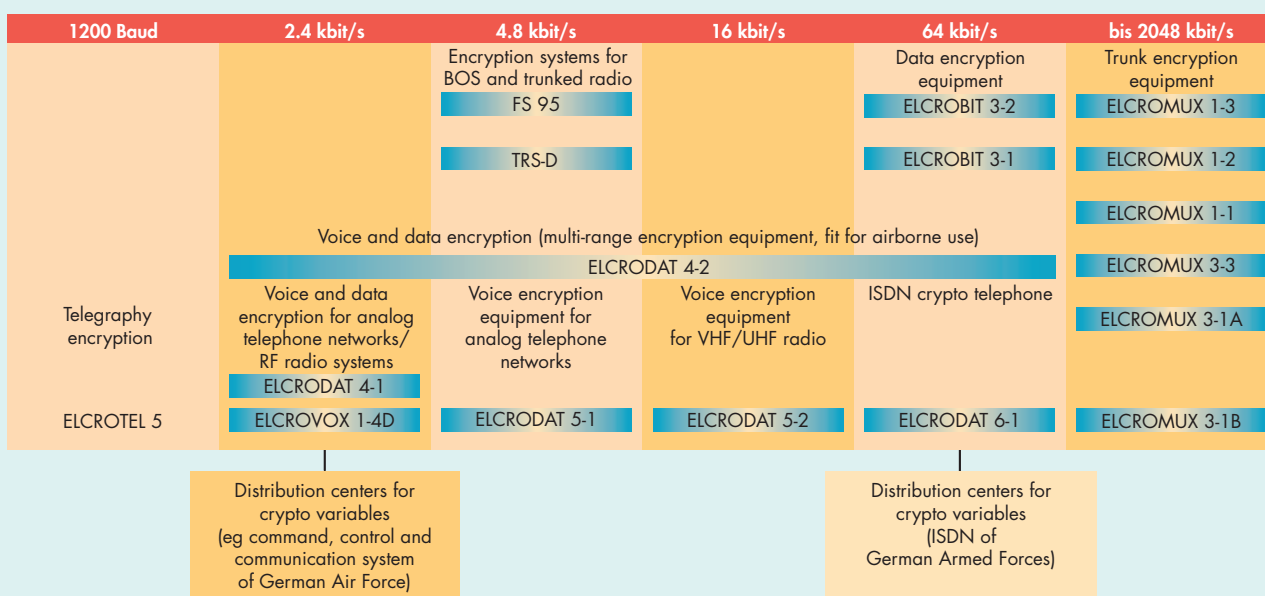

Selection of products produced by SIT in Backnang

- also of uppermost security levels – in hardware and software
- Implementation of mechanisms for the protection of equipment and systems against unauthorized manipulation (tamper protection)
- Protection against compromising radiation through cross-coupling and electromagnetic emission of non-encrypted information (TEMPEST)
- Longstanding experience in evaluation and acceptance of crypto systems of all security classes

In addition to its previous crypto products, SIT can now offer a much wider

security requirements. The figure above gives an impression of the equipment produced at the Backnang plant. The equipment was partly developed in cooperation with Siemens.

Security needs organization

The new team contributes extensive know-how in the conception and implementation of security management systems, which are the basis for an effective and secure operation and administration of all security elements within a communication system. This aspect of applied cryptology is gaining

tools guarantees that the company is not only right up-to-date in the field but also has that certain leading edge in know-how that is critical for defending its customers' information.

Günter Hornauer



Antenna Coupler CTS-Z10/Shielded Chamber CTS-Z12
Simple coupling and interference-free testing in all GSM bands

Anyone engaged in mobile phone testing is only too familiar with problems such as getting hold of a suitable RF adapter or keeping RF levels which would otherwise falsify the measurement results.

Antenna Coupler CTS-Z10 and Shielded Chamber CTS-Z12 are the solution to these problems. As an alternative to coupling via various manufacturer-specific adapters, the RF connection between mobile phone and test set can be made via a single universal antenna coupler. Shielded Chamber CTS-Z12 ensures constant and defined conditions which, without protection measures against external radio fields, are covered by neighboring base stations - are usually not given.

With their excellent RF characteristics in all frequency bands of cellular mobile radio, CTS-Z10 and CTS-Z12 are ideal accessories not only for the Digital Radio Tester CTS, but for all digital and analog radio testers from Rohde & Schwarz.



Digital Radio Analyzer System PCSD detects and analyzes interfering signals. Depending on model, it allows stationary or mobile use, operation in GSM or DAB networks; CIR, C/I or general analyses, frequency range extendible to 2050 MHz.

Data sheet PD 757.4553.21 enter 165/13

Noise Measurement Software FS-K3 (formerly FSE-K3) now also runs under Windows™ 95/98/NT and can be used in combination with Signal Analyzer FS1Q.

Data sheet PD 757.2380.22 enter 165/14

Coupling Networks ENY Double two-wire network ENY22 and four-wire network ENY41 perform standardized EMI emission (150 kHz to 30 MHz) and immunity (150 kHz to 80 MHz) tests on unshielded symmetrical telecommunication ports; Adapter Sets RJ45 optional for ENY41.

Data sheet PD 757.4953.21 enter 165/15



Coupling Networks ENY
for EMI emission and immunity tests on unshielded symmetrical telecommunication ports

- Four-wire and double two-wire networks (EN4)
- Conducted emission measurements to CISPR22 and EN55022 (150 kHz to 30 MHz)
- Conducted immunity measurements to CISPR24 and EN55024 (150 kHz to 80 MHz)
- CISPR A/232/CD compliant with
- Adapter sets to meet ICL requirements (50 dB, 60 dB and 80 dB) and various telecommunication standards
- High transfer bandwidth for useful signal (100 MHz)



Antenna Coupler CTS-Z10 (coupling in 900/1800/1900 MHz band: 10/20/25 dB) and **Shielded Chamber CTS-Z12** (shielding ≥ 35 dB) allow simple coupling and interference-free testing in GSM bands.

Data sheet PD 757.4947.21 enter 165/16

Communication System Panel TS-CSP enables easy and fast integration of measuring instruments into production testing; scalable number of channels, cascading allowing parallel tests, integrated analog measurement functions.

Data sheet PD 757.5072.21 enter 165/17

Power Sensors NRV-Z (DC to 40 GHz, 100 pW to 30 W) The complete range of power sensors for NRV, NRVs, URV35 and URV55 from Rohde & Schwarz is now covered by this data sheet.

Data sheet PD 756.9797.22 enter 165/18

Absorbing Clamps MDS-21, MDS-22 and Ferrite Clamp EZ-24 The new ferrite clamp for reproducible interference field-strength measurements (1 to 1000 MHz) is designed for line diameters up to 22 mm; maximum skin current RF power 50 W.

Data sheet PD 756.5085.25 enter 165/19

MPEG2 Measurement Generator DVG, Stream Combiner™ DVG-B1 Suitability for ATSC is included in the new data sheets.

Data sheets
DVG: PD 757.2738.23 enter 165/20
DVG-B1: PD 757.3611.23 enter 165/21



UHF Transmitter Family NH7000 (analog TV; 2 kW to 40 kW) and **NV7000** (DBV-T; 400 W to 5 kW) (see article on page 11).

Data sheet PD 757.5089.21 enter 165/22



UHF Transmitter Family NH/NV7000
Liquid-cooled transmitters for analog and digital TV (DVB-T)

- Frequency range 470 MHz to 860 MHz
- Advanced IDAMOS technology for power amplifiers
- Digital premodulation
- Liquid-cooled
- High redundancy
- Highly compact for minimum space requirements
- Cost-effective installation
- All sterility concepts possible (single transmitter, active or passive robot-stage standby, source standby)

Communication System Panel TS-CSP
Easy and fast integration of measuring instruments into production testing

- Acquisition and switching of DUT signals for functional tests and final testing
- Scalable number of channels for multipositional board tests as well as simultaneous testing on several modules
- Efficient acquisition of RF signals using RF Switch Matrix TS4FM
- Integrated analog measurement functions and flexible switching using Universal Switch Matrix TS4SM
- Input and generation of digital signals, adjustable signal levels
- Control via EC/IEEE bus or high-speed PC card interface



Series 200 Multichannel Communication System (118 MHz to 144 MHz, 25 W and 50 W/225 MHz to 400 MHz, 30 W). Besides single-channel variants there are now also multichannel systems for ATC communication (channel spacing 25 kHz or 8.33 kHz) designed for local or remote control and having the same features.

Data sheet PD 757.4847.21 enter 165/23

HF Transceiver RS150T (1.5 MHz to 30 MHz, 150 W; reception above 10 kHz) features excellent RF characteristics and is compatible with Series XK2000 and HF850; all other transmission types, ALIS or ALE are integrated; control elements, tuning unit, HF modem and further components are part of Series 150.

Data sheet PD 757.3957.21 enter 165/24

Voltage and Power Measurements This brochure has been revised and updated.

Info PD 757.0835.13 enter 165/25

Refresher topics – Television technology Given the importance of new technologies PAL-plus, digital studio signal, data reduction, MPEG2 and DVB, Professor Mäusl has revised and updated this brochure. Parts that are no longer relevant have been omitted.

Info PD 757.8990.23 enter 165/26

New application notes

Frequency Response Measurements
1MA09_3E enter 165/27

Application Software MobilDemo
1MA11_1E enter 165/28

Schz

Fit for new data services

Mobile radio was one of the topics in the August edition of the German journal "ntz", and the journal makers chose to put the Rohde & Schwarz HSCSD logo on the front cover.

Under the title "Fit for new data services", the issue presented HSCSDs and Rohde & Schwarz's new Digital Radiocommunication Test Set CRTC. This measurement solution is designed to handle the new, fast data services. Says the article: "Digital Radiocommunication Test Set CRTx-SAT allows HSCSD tests with maximally 2+2 multislot links..."



Smallest measurement uncertainty worldwide

The front cover of the monthly "Elektronik Revue" regularly features the outstanding news of the month.

In its 10/99 edition, this included the new Spectrum Analyzer FSP from Rohde & Schwarz. The caption read: "The variety of standard functions offered in the portable Spectrum Analyzer Family FSP with frequency limits 3, 7, 13 and 30 GHz is unrivalled in the medium price range. ... Its 0.5 dB measurement uncertainty is the smallest worldwide."

Complete package for EMC measurements

This was the title chosen by "HF-Praxis" for its article on the EMIPAK solution from Rohde & Schwarz in its September edition.

"EMIPAK from Rohde & Schwarz is a powerful and inexpensive all-in solution for precompliance EMC measurements."

EMC measurements for today's needs

An issue dedicated to T & M technology was the autumn special for 1999 published by "Design & Elektronik". Its September front cover featured a photo of the new EMI Test Receiver ESI from the T & M specialist Rohde & Schwarz.

"EMC measurements for today's needs" was the subject of the editorial. It described the requirements of today's EMC measuring instruments and commented on the new ESI family from Rohde & Schwarz: "Today's market calls for highly versatile equipment that is easily integrated into existing systems, features high measurement speeds, but is still simple to operate. Beside RF characteristics, these were the requirements that Rohde & Schwarz engineers had in mind when developing their new ESI family of EMI test receivers."

Photo 43 335/3

Digital pioneers

This was the title of an article in edition 6-7/99 of the journal "Communications Africa", which has a worldwide circulation.

The article reported on the development of digital television in Africa and – with pictures as well as text – on Coverage Measurement System TS6200 from Rohde & Schwarz.





Broadcasting highlights at IBC99 in Amsterdam

The 1999 IBC from 10 to 14 September in Amsterdam was quite a landmark event for Rohde & Schwarz. The company presented its NV7000 product family, an entirely new generation of transmitters for digital and analog television. They feature innovative hardware design, operating with liquid-cooling and newly developed amplifiers, which enables a more than 50 % reduction in space requirements. This compactness attracted the visitors, who milled about the Rohde & Schwarz stand in large numbers to admire the new product (see also page 11).

If this was not impressive enough, the visitor only had to turn to Rohde & Schwarz T & M. EFA-T is a new TV test receiver for DVB-T offering the functions of an OFDM analyzer and combining analog and digital demodulation in a single unit

(see News 164). The innovative design of MPEG2 Recorder/Generator DVRG and MPEG2 Realtime Monitor DVRM put these two units in the focus of visitors' interest too. DVRG records and demultiplexes MPEG2 transport streams according to DVB and ATSC. The resulting elementary streams can be remultiplexed to generate new transport streams. DVRM was especially developed for network operators (see also page 14).

Rohde & Schwarz joined the world

Telecom – held in Geneva only once every four years – is one of the world's major telecommunication showcases. Beside global players working the telecommunication market, Telecom also attracts decision-makers and leading personalities from politics, business and research. The motto of this year's show was "Join the World", and the list of attending companies showed that it was well justified. Rohde & Schwarz, with its own stand in the German Pavilion, focused in its presentation on the new Monitoring Receiver ESMB, which is in line with ITU requirements, on IT security, radiomonitoring, spectrum management, TETRA as well as test and mea-

surement equipment for third-generation mobile radio.

At the opening ceremony of Telecom 99, UN Secretary General Kofi Annan, the guest speaker, stressed the role of telecommunication as a force paving the way into the future and appealed to industry to make affordable communication solutions available throughout the world.

Partnership between Rohde & Schwarz Cologne and eidon

Rohde & Schwarz in Cologne and eidon GmbH, based in Erlangen, agreed on cooperation aimed at mutual support in projects dealing with technical documentation as well as in sales and support for eidon-Xbase, software for documentation and publishing management. eidon has been active in the market for documentation and information systems for ten years and offers software products as well as comprehensive services in the development of system solutions for medium-sized and large companies from different branches of industry.

First functional solution for Web over DVB worldwide

The spread of Internet – regarded as the major communication platform of the future – is still impeded in many areas by difficult access and high cost. Web over DVB, recently developed by Rohde & Schwarz, is the first functional solution worldwide



for Internet access over a TV antenna. Selected Internet data in IP format are inserted into the MPEG2 data stream and transmitted together with the TV signal. The data are then stored in the user's computer and called up by standard Web browsers. This extremely simple and low-cost solution for distribution of Internet resources met with great interest among visitors to the "Digital Signs" exhibition held in Munich in October 1999.

With Web over DVB, Internet data are made available in push technique. The TV broadcaster can define which data are to be transmitted to which user groups.

"100 years signal corps" – exhibition in Signal School at Feldafing

To mark its 100th jubilee, the Signal School and Army School of Electrical Engineering at Feldafing in Bavaria presented an extensive exhibition titled "100 years signal corps" on 1/2 July 1999. Equipment and systems used by the German forces were on display as well as new and innovative products. Renowned companies like Bosch, Daimler Chrysler Aerospace, Elekluft, ESG, Rohde & Schwarz and SEL showed examples of what the signal corps might be using tomorrow.



Possible scenarios may include Internet pages of the program provider with the latest news or multimedia information such as video and audio sequences. The advantage of Web over DVB is its easy and cost-efficient implementation by existing resources – the TV signal and its emission. For the first time, users can be provided with Internet data without conventional means of access.

The Multiband, Multimode, Multirole Radio from Rohde & Schwarz raised particular interest. Visitors saw an operational M3TR, as it is called, demonstrating its capabilities by setting up a radio link with the German army's handheld radiotelephone SEM52 from the company SEL. Another demonstration by Rohde & Schwarz consisted in setting up a shortwave link to company headquarters in Munich by means of "Space-man". From there, a further link

was established to the Internet and to German army units in Sarajevo. This enabled news from the various locations to be retrieved on the screens at Feldafing via TV satellite. The high-ranking representatives of the German armed forces and of allied nations who attended were able to gain a vivid impression of the uses of Rohde & Schwarz radiocommunication solutions in practice.

TV transmitters for DVB-T network in Spain – a multimillion order

A new order strengthens the global position of Rohde & Schwarz as market leader in the field of DVB-T transmission. The company received an order to supply TV transmitter technology for the creation of a DVB-T network in Spain. Following the network set up in Britain, this is the second large DVB-T project to be launched with Rohde & Schwarz solutions for modern broadcasting.

In this project – carried out by Spanish network operator Retevisión – Rohde & Schwarz will be providing some 60 high-power transmitters and more than 100 DVB modulators. The key factors in favour of Rohde & Schwarz were the liquid cooling of the transmitters, the ability to deliver fast and the price/performance ratio of the systems. Further important criteria were high availability and the possibility of convenient service during ongoing operation.

Stefan Böttinger

Y2K hotline for millennium entry

Tests for Y2K compatibility of Rohde & Schwarz products as well as its internal business and production processes are virtually completed. As a result, it can now be guaranteed that all internal Rohde & Schwarz processes are year-2000 safe. This was confirmed by an external audit conducted by the TÜV Rheinland, which concluded that, based on all information presently available, the vast majority of Rohde & Schwarz products are Y2K compatible. The website www.rsd.de can be consulted for a comprehensive list of all units and their year-2000 characteristics. The list also indicates products for which Y2K software updates are obtainable from local representatives.

Despite all these precautions, there will still be a Rohde & Schwarz hotline operating round the clock at the beginning of the new year. A team of some 25 specialists will be available for queries, problems and immediate assistance from 12:00 h on 31 December 1999 through 08:00 h on 3 January 2000. The hotline can be contacted worldwide under:

Phone: +49-1-805-124242

Fax: +49-89-4129-6974

E-mail:
year2000.helpdesk@rsd.rsd.de

How random is chance?

(part 2 and conclusion)

How can quality of random bit sequences be tested?

In the first part of this article, which appeared in NEWS 164, we explained why random numbers are generated and used. Looking at such bit sequences you might get the impression that they resemble "ideal" random sequences. But if quality requirements are high, how can they be tested in a simple way to prove that they are really "random"? This question is of vital importance in practice since you must ensure that keys for crypto systems, as implemented for example in Rohde&Schwarz communication equipment used by embassies, cannot be cracked or calculated due to some kind of deficiency.

In the terminology of mathematical statistics the criteria of this objective are defined as follows: the bit sequence of length n is to match the random hypothesis of being a realization of a random vector with n components that are distributed independently and identically according to the discrete, uniform distribution function across set $\{0, 1\}$.

Similarly to other statistical tests, tests provide only probability values that may exhibit certain errors. Despite the use of generation methods that come very close to an "ideal" random generator, a sequence with certain regularities may result. On the other hand, it is also possible for bit sequences to successfully pass several tests even though they exhibit distinct regularities.

What are the usual test methods?

The most obvious method would be to count ones and zeroes in a bit sequence and compare their number. If the two counts differ substantially, the theoretical objective mentioned above is not met. This criterion is also demanded in US standard FIPS-Pub 140-1: in a sequence of 20000 bits the number of ones shall be between 9654 and 10346.

The bit sequence 010101010101... meets this requirement for example, although it has a very simple structure. This shows that other test criteria are required, eg comparison of the number of agreements between two successive bits (00 or 11) with the number of



disagreements (01 or 10). In practice, bit sequences are also divided into segments of a certain length and the frequency of segments is counted (eg the frequency of byte segments for a length of 8 bits). In a "real" random sequence these segments should occur in almost identical numbers.

However, there are also sequences that meet the above-mentioned criteria but still show strong regularities. These include sequences produced by linear generation rules (eg originating from linear feedback shift registers).

There are also sequences that contain one long segment (or more) of the form 000...0 or 111...1. The US standard mentioned demands, for example, that

in the case of 20000 bits such segments with a length of 34 bits or more are not to be part of the sequence.

Some other test approaches

- Tests that examine to what extent compression (eg "pkzip", a method widely used in the PC field) reduces the amount of data. If compression is high, the bit sequence has a lot of redundancy, ie regularity, something that is not to occur in an ideal random sequence.
- Test approaches according to the autocorrelation principle. A sequence of characters is copied, shifted by a certain amount and linked to the original. The data thus obtained are examined (eg by frequency analysis).
- Test approaches by which regularities of certain pseudo-random sequences can be found, for example, that were created by standard software functions. Single bits are sampled at certain intervals (eg every 16th bit) and tested to certain criteria.
- One bit sequence is subjected to a Monte Carlo (see part 1) calculation (the sought surface contents must be known). If the result is close enough to the surface contents, the bit sequence has passed the test.

Further interesting tests are performed by the Diehard software from the University of Florida. Two examples:

- Bit segments of a sequence are each written in a matrix to a certain rule and the rank of each matrix is determined. The calculated ranks have to exhibit a behaviour like the ranks of random 0-1 matrixes.

- Coordinates of points are formed from bit segments and entered into a square. The smallest distance between two points is calculated.

Finally a test approach that relates to a known combinatorial problem (the "coupon collector problem"). In this case you calculate how many bit segments of a certain length are required until each segment occurs at least once. The theoretical basics for this also apply when discussing the question of how many chocolate eggs have to be bought to get all the playthings of a certain series contained in them with high probability (precondition: uniform distribution of contents).

The above statements show that testing "chance" properly is a very difficult business. There are an infinite number of possible tests when you think about it. And you have to consider generation methods and planned applications when choosing tests. The larger the number, variety and scope of the test passed is, the more sure you can be of the randomness of the sequences generated.

Dr Ralph Wernsdorf

REFERENCES

- R. Zielinski: Erzeugung von Zufallszahlen. Fachbuchverlag Leipzig, 1978.
- P.H. Müller (Hg.): Lexikon der Stochastik, Akademie-Verlag Berlin, 1991.
- R. Wobst: Abenteuer Kryptologie. Addison-Wesley, 1998.

Reader service card 165/29

Visit us on Internet at www.rsd.de



ROHDE & SCHWARZ GmbH & Co. KG · Mühlendorfstraße 15 · 81671 München · P.O.B 80 14 69 · 81614 München
Support Center: Tel. (+49) 018 05 12 42 42 · E-Mail: customersupport@rsd.rsd.de · Fax (+49 89) 41 29-3777